

Simulation of Induction Motor Characteristics Using A Circle Diagram

Alina Meishele (*PhD student, Riga Technical University*), Elena Ketnere (*Dr.Sc.ing., Riga Technical University*), Aleksandrs Mesnyayevs (*PhD student, Riga Technical University*).

Abstract – The circle diagram helps to identify all electromagnetic values, which describe the machine’s operation mode at different slip values and gives them a better description when machine’s operating mode is changing.

The circle diagram is also of great importance for studying the case, when the parameters of the asynchronous machines operating mode are assumed to be constant values.

Keywords – Circle diagram, heavy-duty induction motor, mathematical simulation.

I. INTRODUCTION

In general, mathematical modeling opens new perspectives for studying the electric machines. The possibility to replace real objects with the mathematical model provides great advantages for the development and research of electric machines. As it is known, one of the most popular forms of the electric drive is the induction motor. It is related with the simplicity of manufacturing and the highest safety of induction motor.

Modern technologies drive the engineering industry for the increase of the produced electric machines power. During the tests of a new machine, it is not always possible to load the machine according to its power. In such cases, if the appropriate technical supply is not available in order to receive the necessary curves for electric motors with the power over 100 kW, it is possible to measure the efficiency, power factor and slip values, by using a circle diagram.

For the convenient view of the circle diagram, it is appropriate to use the equivalent circuit of the asynchronous machine (Figure 1.).

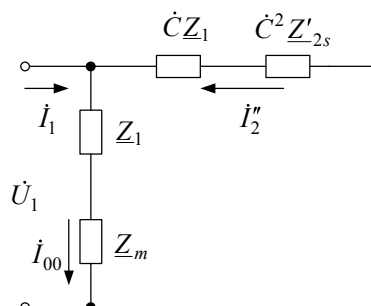

Fig. 1. The equivalent circuit of the asynchronous machine.

According to the equivalent circuit (Figure 1), the stator current can be determined by adding the constant idle current I_{00} to the variable component - I_2'' . So, it is obtained a

simplified induction motor circle diagram, as shown below (Figure 2).

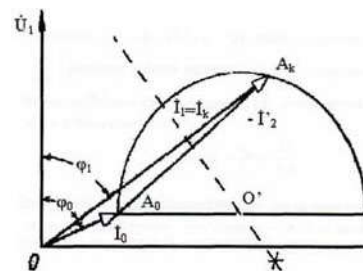

Fig. 2. A simplified construction of the induction motor circle diagram.

$$\dot{I}_1 = \dot{I}_{00} + (-\dot{I}_2'') \quad (1)$$

where

$$I_{00} = \frac{U_1}{Z_1 + Z_m} \quad (2)$$

I_{00} - is the ideal idle current, and does not depend on the slip ($s = 0$). This current is constant, since $U_1 = const$ and $f_1 = const$. Therefore, the coordinates of the beginning are to be transferred to the I_{00} value, and, as the result, the circle diagram is acquired (Figure 3). [1]-[3]

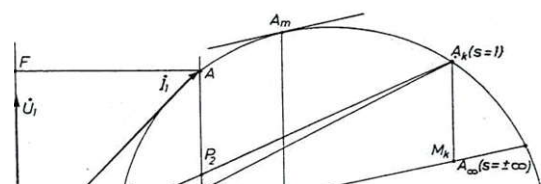

The results of student’s practical work based on experiments were taken to prove the precision of this program. Nominal parameters are given in the table 1.

TABLE I

THE THREE-PHASE INDUCTION MOTOR WITH A PHASE ROTOR

Nominal parameters	
Nominal voltage U_N	220 V
Nominal current I_N	28 A
Nominal power P_N	7.5 kW
Nominal speed n_N	945 (min ⁻¹)
Power factor $\cos\varphi$	0.83
Efficiency η	0.84
Stator winding resistance R_{stat}	0.183 Ω

Using the measurement results, the circle diagram was constructed, which allowed to determine the performance curves (see fig.4).

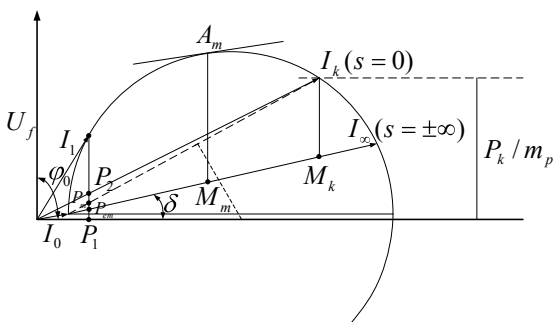

Fig. 4. The three-phase induction motor’s circle diagram.

The figure 4 shows the circle diagrams, which have been created using the Microsoft Office Visio program. The operating characteristics are shown on the figure 5.

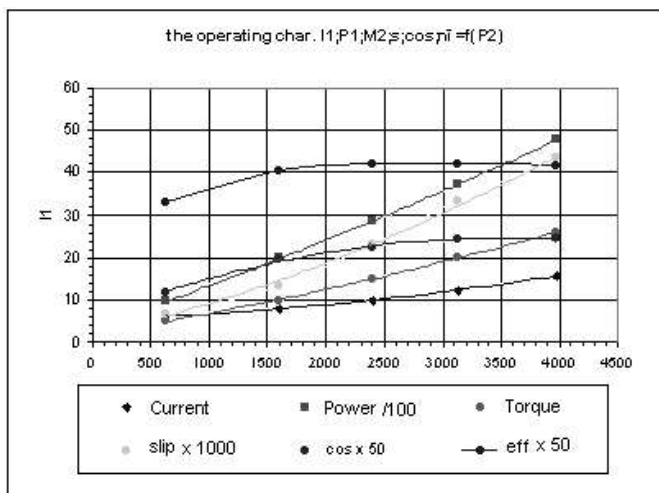

Fig. 5. The operating characteristics

For the comparative reasons, the calculation also was made using the program “Diagram”. On the basis of the idle and short circuit test results, this program calculates the parameters, which are required for the construction of circle diagrams. The program calculates the operating and start-up characteristics with the assistance of a circle diagram.

For operating the program, it is essential to enter the following parameters: the stator winding resistance R_1 , the ambient temperature T , the synchronous rotation frequency n_1 , the nominal (phase) voltage U_{1N} , the nominal current I_N , the idle current I_0 , idle losses P_0 , mechanical losses P_{meh} , the short circuit voltage U_k (the voltage, under which the nominal current is achieved) short-circuit losses (losses corresponding nominal current) P_k .

The program will process them and generate a circle diagram parameters, such as: the radius of diagram, the circle center in the complex plane, the point of synchronism, the idle point, the short-circuit point, the infinite slip point. The program will also generate such nominal parameters as: the power factor, supply power, useful power, efficiency, slip and torque. The program also generates the operating characteristics and the start-up characteristics, which allow to determine the starting current, the starting torque, the maximum torque and the critical slip.

After obtaining all these values, the circle diagram can be drawn. Results were used to construct operating and start-up characteristics with help of Microsoft Office Excel as shown on figure 6 and 7.

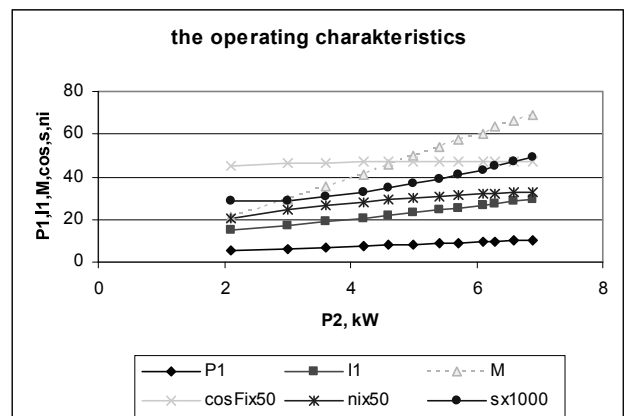

Fig. 6. The operating characteristics (based on the program data).

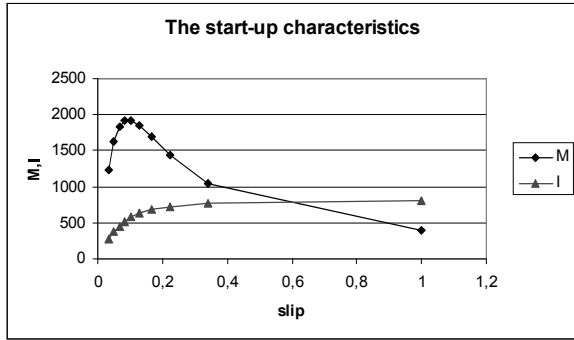

Fig. 7. The start-up characteristics (based on program data).

Comparing the results, which were obtained manually, and the ones, using the program "Diagram", it is concluded that they partially coincide. The manually executed calculations are not precise enough due to the human factor. Using the computer program, it is possible to obtain the necessary parameters and characteristics with no additional time losses, which occur while constructing the manual diagram.

The further program test was executed using the three-phase traction motor "DTA 170 U2". This motor is a part of the asynchronous track drive for the underground car 81-760/61 developed by the «Metrovagonmash». The motor parameters are given in table 2.

TABLE II
THE TRACTION MOTOR PARAMETERS

Stator winding resistance R_1	0.0397 Ω
The ambient temperature T	20°C
Synchronous rotation frequency n_1	1500 min ⁻¹
Nominal power P_N	170 kW
Nominal (phase) voltage U_{1N}	306.4 V
Nominal current I_N	225 A
The idle current of I_0	75.5 A
Idle losses P_0	7.77 kW
Mechanical losses P_{meh}	0.7k W
Short circuit voltage U_k	85 V
Short circuit losses P_k	12 kW

The aim of research is to prove that it is possible to obtain working performances for asynchronous motor with power over 100 kW using program "Diagramm". For comparison the test results of motor "DTA 170U2" are given.

The results obtained by operating the program "Diagram" are compared with the measurement results obtained by the electrical equipment test center (shown on the figures 8, 9).

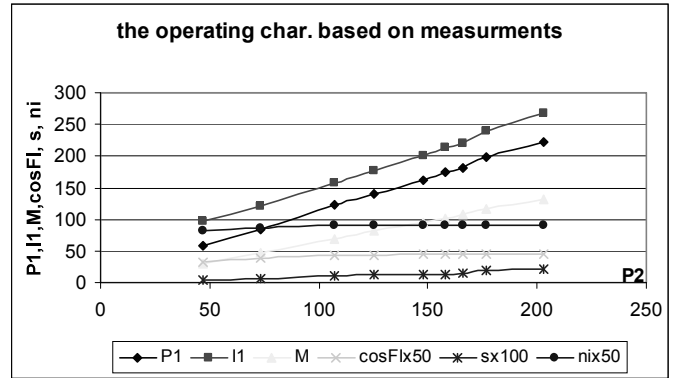

Fig. 8. The operating characteristics based on measurements.

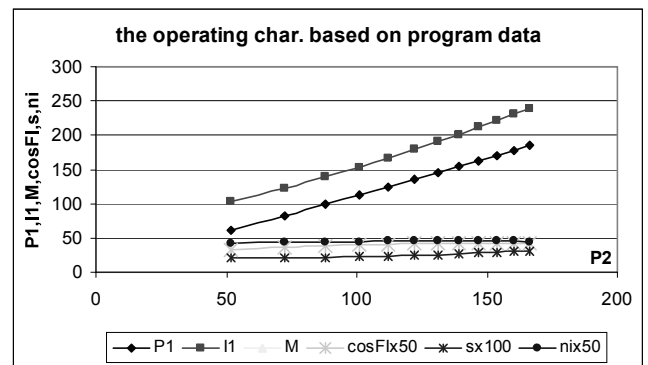

Fig. 9. The Operating characteristics, based on the program "Diagram".

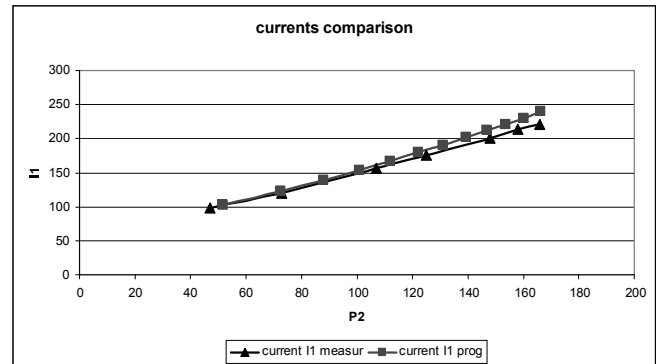

Fig. 10. The comparison of current characteristics.

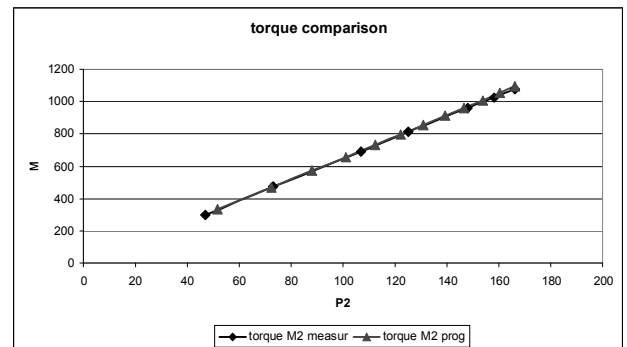

Fig. 11. The comparison of torque characteristics.

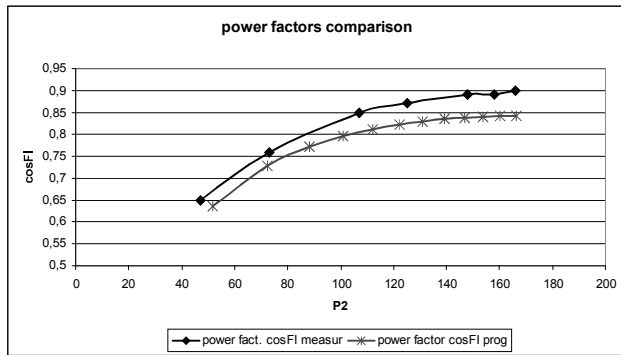

Fig. 12. The comparison of power factor characteristics.

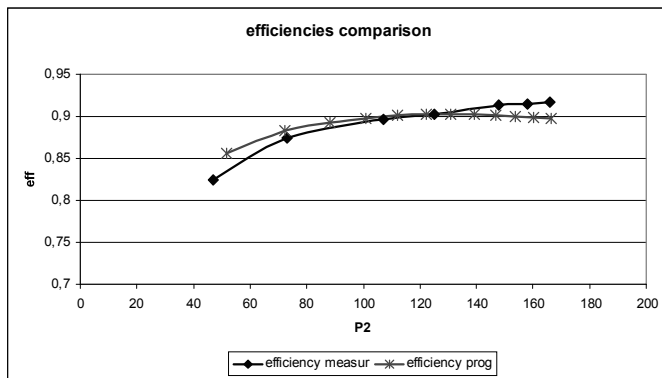

Fig. 13. The comparison of efficiency characteristics.

As it is shown on the figures 10-13, the parameters obtained by measurements and by calculation with the program “Diagram” are identical. The statistical error doesn’t exceed the affordable limits. Therefore, the program “Diagram” can be used for operating characteristics.

III. CONCLUSIONS

All motor’s performances, which determine its condition (starting, operating and control) is possible to obtain from experiments. But to do so, it is necessary to have corresponding equipment, a lot of time and energy, especially for high-power motors. That reasons causes difficulties for calculation of each performance while constructing a motor. From this point of view it is understandable that simulation of these performances is preferable.

As it is presented on the figures 6 – 13, the program “Diagram” provides satisfactory results for motors with different nominal parameters. Thus, this program can be used in cases when direct measurements are impossible.

This simulation allows substituting measurements with calculations, when is necessary to research different static modes.

REFERENCES

- [1] A.Zviedris Elektriskās mašīnas. Rīga, “Zvaigzne”,1984.
- [2] М.М. Кацман Лабораторные работы по электрическим машинам и электроприводу. М. «Академия», 2002.
- [3] А.И.Вольдек, В.В.Попов. Электрические машины. Машины переменного тока. Учебник для вузов. СПб.:Питер, 2008.



Alina R. Meishele is born in 1984 in Latvia. In 2008, she graduated the Riga Technical University, obtaining the M.Sc.ing. degree. Presently she is a PhD student. In March 2007, she received the certificate “AutoCAD 2007”.



Elena K. Ketnere is born in 1963 in Latvia. In 1985, she graduated the Riga Polytechnical Institute (RPI), the Faculty of Electrical and Power Engineering, obtaining the qualification of Engineer in the Electrical Machines and the Apparatus specialty. In 2002, she obtained the Dr.Sc.ing. degree.

After graduating the RPI, E. Ketnere has worked as an engineer at Riga Electric Machine-building Plant (1985-1995). In 2005, she was appointed as the Associate Professor in the Department of Electrical Machines and Apparatus of the Riga Technical University, where she works

up to date.

Scientific activities of E.Ketnere are related to the Mathematical Simulation of the dynamic regimes of the Electrical Machines. The results of her research are reflected in more than 20 scientific publications and technical reports in International Scientific conferences.



Aleksandrs A. Mesnyayevs is born in 1985 in Latvia. In 2008, he graduated the Riga Technical University, obtaining the M.Sc.ing. degree. At present, he is a PhD student. In March 2008, he received the certificate “Basic and advanced simulation using QuickField software”.

Starting from 2006, he is working as a laboratory assistant and a scientific assistant in the Department of Electrical Machines and Apparatus of Riga Technical University.

Tel. +371 67089928, E-mail: kbl@inbox.lv