

CO.5

PERFORMANCE EVALUATION OF WDM AND TDM PASSIVE OPTICAL NETWORKS

Sandis Spolitis¹, Girts Ivanovs²

¹Riga Technical University, Institute of Telecommunications, Azenes 12, Riga, Latvia; phone: +37126151611; E-mail: sandis.spolitis@rtu.lv

²Riga Technical University, Institute of Telecommunications, Azenes 12, Riga, Latvia

Optical transmission is getting more popular in the access network due to the increasing demand for bandwidth. This paper introduces an overview of Wavelength-Division-Multiplexed Passive Optical Network (WDM-PON) technology and Time-Division Multiplexing Passive Optical Network (TDM-PON) as well as different passive optical network architectures such as Gigabit PON (GPON), Broadband PON (BPON) and Ethernet PON (EPON). The advantages and disadvantages of each PON architecture is shown in the theoretical part of this research and the comparative results are provided. The experimental part of this research is focused on the investigation of high speed long-reach WDM-PON network.

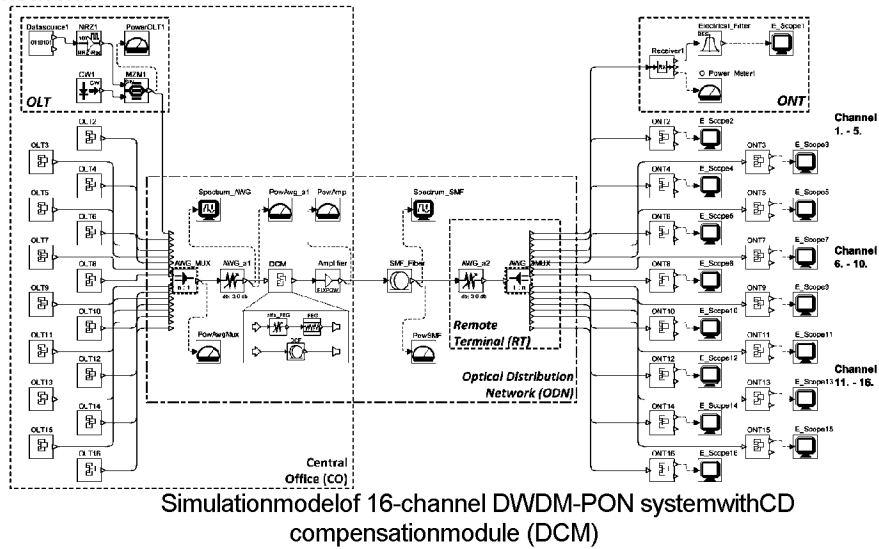

Chromatic dispersion (CD) compensation is an important premise to achieve higher performance of long-reach DWDM-PON fiber optical system and increase the maximum transmission distance from OLT to ONT. In this research using OptSim 5.2 simulation software we have built simulation scheme and investigated maximum reach extension of the long-reach high speed 16-channel DWDM-PON system using the compensation of accumulated CD. In our research DCF fiber and FBG are used in dispersion compensation module (DCM) to compensate accumulated CD value.

The maximum reach of realized DWDM-PON system without CD compensation was 57 km, but it has been shown that using described CD compensation methods (DCF and FBG) system maximum reach can be improved. Using additional 7 km long DCF fiber the 16 channel DWDM-PON system maximum link length between OLT and ONT was improved by 19.3% or 11 km in length – from 57 km to 68 km. The best results were obtained by using FBG for CD compensation. DWDM-PON system simulation model with FBG was able to provide data transmission with BER < 10⁻⁹ in length of 72 km. In case when FBG is used for CD compensation DWDM passive optical network reach can be improved by 26.3% or 15 km in length – from 57 km to 72 km. This result can be explained by the fact that FBG has relatively small insertion loss (<4dB) and instead of DCF fiber it can be used at higher optical powers without inducing nonlinear optical effects, which can reduce the system's performance.

Basis on the results authors recommend the use of FBG for chromatic dispersion compensation to increase the maximum transmission distance of future high speed long-reach DWDM-PON systems.

ACKNOWLEDGMENT

This work has been supported by the European Regional Development Fund in Latvia within the project Nr. 2010/0270/2DP/2.1.1.0/10/APIA/VIAA/002 and by the European Social Fund within the project „Support for the implementation of doctoral studies at the Riga Technical University”

Keywords: Wavelength division multiplexing, passive optical network, chromatic dispersion compensation.