

RIGA TECHNICAL UNIVERSITY

Zita DREIJA

**RESEARCH OF TECHNOLOGICAL PROCESS
FOR ASSEMBLY OF CYLINDRICAL PARTS
SET BY INTERFERENCE FIT**

Summary of doctoral dissertation

Field: Mechanical Engineering
Sub-field: Technology of mechanical engineering

Riga 2012

RIGA TECHNICAL UNIVERSITY
Faculty of Transport and Mechanical Engineering
Institute of Technology of Mechanical Engineering

Zita DREIJA

PhD student of doctoral study program „Apparatus Engineering”

**RESEARCH OF TECHNOLOGICAL PROCESS
FOR ASSEMBLY OF CYLINDRICAL PARTS
SET BY INTERFERENCE FIT**

Summary of doctoral dissertation

Field: Mechanical Engineering
Sub-field: Technology of mechanical engineering

Scientific Advisor
Dr. Sc. Eng., Asoc. Professor
Fr.SUDNIEKS

Scientific Consultant
Dr. Sc. Eng., Professor
O.LININSH

Riga 2012

UDK 681.2+621.717](043.2)
Dr285 c

Dreija Z. Research of technological process for
assembly of cylindrical parts set by interference fit.
Summary of Doctoral dissertation. -R.: RTU, 2012.-26
pages.

Printed in accordance with decision of the Institute of
MET taken on 2011. 12. April, protocol No. 4/11.

**DOCTORATE PAPER
NOMINATED IN THE RIGA TECHNICAL UNIVERSITY FOR OBTAINING OF
DOCTOR'S DEGREE IN ENGINEERING**

Doctorate Paper for obtaining of doctor's degree in engineering shall be presented in public on, 2012 in the Faculty of Transport and Mechanical Engineering of the Riga Technical University in Ezermalas street 6, study room No.405.

OFFICIAL REVIEWERS

Professor, Dr.sc.eng. Eduard Shevtshenko (Eduard Ševtšenko)
Tallinn University of Technology

Professor, Dr.sc.eng. Gunars Verdins (Gunārs Vērdiņš)
Faculty of Engineering, Latvia University of Agriculture, Latvia

Professor, Dr.sc.eng. Juris Krizbergs
Riga Technical University, Latvia

ACKNOWLEDGMENT

Herewith I confirm that I have developed this Doctorate Paper submitted for review to the Riga Technical University for obtaining of doctor's degree in engineering. The Doctorate Paper is not submitted for obtaining of academic degree to any other university.

Zita Dreija(Signature)

Date:

The Doctorate Work is written in the Latvian language. It consists of introduction, 6 chapters, conclusions, and bibliography with 94 items, 61 figure, and 8 tables. The Doctorate Work contains 124 pages in total.

CONTENTS

| | |
|--|----|
| GENERAL CHARACTERISTICS OF THE DOCTORATE PAPER | 5 |
| Topicality of theme | 5 |
| Aim and tasks of the paper | 5 |
| Methods of research | 6 |
| Scientific innovation of the paper | 6 |
| Practical application | 7 |
| The following theses are set forth for defence | 7 |
| Approbation of the paper..... | 7 |
| Publications | 8 |
| Volume of the dissertation and description of structure | 8 |
| Content of dissertation | 8 |
| Introduction | 8 |
| 1. REVIEW OF BIBLIOGRAPHY | 8 |
| 2. DETAILS BASING AT AUTOMATIC ASSEMBLY..... | 10 |
| 3. ACCURACY DETERMINATION OF TECHNOLOGICAL PROCESS FOR AUTOMATIC ASSEMBLY | 11 |
| 4. FEATURES OF CYLINDRICAL PARTS SET BY INTERFERENCE FIT INFLUENCE ON ASSEMBLY..... | 14 |
| 5. STRENGTH ENSURING OF CYLINDRICAL PARTS SET BY INTERFERENCE..... | 14 |
| 5.1. Determination of stresses and deformations for the cylindrical parts set by interference . | 14 |
| 5.2. Method of engineering calculations for cylindrical parts set by interference fit development by using 3D regular case field theory | 16 |
| 5.3. Method and example of engineering calculation of interference fit for cylindrical parts.. | 19 |
| 5.4. Impact of roughness parameters Ra and Sm of contacting surfaces on capacity of interference fit and load in contact research..... | 21 |
| 6. EXPERIMENTAL RESEARCH OF ASSEMBLY FEATURES OF CYLINDRICAL PARTS SET BY INTERFERENCE FIT | 22 |
| CONCLUSIONS..... | 24 |
| BIBILIIOGRAPHY | 26 |

GENERAL CHARACTERISTICS OF THE DOCTORATE PAPER

Topicality of theme

Pressing-in assembly of cylindrical parts set by interference fit in manufacturing of equipment is an often applicable method of details assembly and it composes about 35% of the total amount of details assembly. Development of technologies in mechanical engineering and metal-working, especially, demand for higher accuracy in manufacturing of details for fields of mechanical engineering provides increasing use of such assemblies. Trajectory assembly movement of cylindrical parts is rather simple. It provides possibility to get such parts in assembly automates.

In order to obtain mating of cylindrical parts with the required quality, one of the most labour-consuming stages of the assembly process in assembly automates is providing of correct orienting and location of assembly details in the position of assembly. Researches on accuracy of mutual orientation of cylindrical details and safety of effectuation of the technological process of assembly are performed by several authors: A. Rabinovich, K. Muceniaks, Fr. Sudnieks, A. Malov, V. Kosilov, M. Novikov, and N. Gusejnova. Researches prove that pressing-in with vibration impulses increases strengths of connections in comparison to regular pressing-in (in press). However, this method is less effective due to reduction of surface roughness of mating details during pressing of details. Analysis of bibliography certifies that notwithstanding the existing researches, condition of automatic assembly of cylindrical parts set by interference fit defining admissible allowance in assembly of details is insufficiently researched. The reviewed works have not considered parameters of surface roughness R_a and S_m , which affect the process of assembly substantially.

To design assembly automates for pressed parts; capacity of power needed for pressing-in shall be defined. For providing of assembly of details with interference fit by pressing, reserve of pressing power is necessary. Currently, defining of capacity of pressing power is related to difficulty because it involves determination of several parameters with complicated causality. For example, changes of friction coefficient and parameters of surface roughness of assembly details in the process of pressing as well as defining of contact pressure, which depends on interference. The current method for calculation of pressed part interference fit is not accurate enough considering that cylindrical details are a dimensional object; therefore, roughness parameters corresponding to real surface shall be defined. In order to characterize roughness of surface profile, one parameter R_a is not enough. Demand for more precise method of calculations is facilitated by development and progress of mechanical engineering, which asks for more and more accurate equipment, long-time resistant part with high durability.

The above described conditions give rise for further researches of assembly process of cylindrical parts set by interference fit in automatic equipment. New and improved methods of engineering calculations for assembly of cylindrical parts set by interference fit and development of method for forecasting of the part durability is considered topical.

Aim and tasks of the paper

The aim of the paper is to research the impact of technological process of automatic assembly of cylindrical parts set by interference fit and parameters of details on the contact of assembly details and values characterizing it. Basing on this research, method of engineering calculations for cylindrical parts set by interference fit shall be developed.

For reaching of the aim, the following tasks were defined:

- 1) To determine the admissible failure in mutual layout of axes of cylindrical details designed for automatic assembly in position of assembly in order to provide the necessary choice of basing schema.
- 2) To perform research of impact of geometrical parameters of details and roughness parameters of contact surface of details on durability of cylindrical parts set by interference fit and on process of assembly for orientation of details in position of assembly.
- 3) To develop mathematical model for defining of durability of part set by interference.
- 4) To develop method of engineering calculations for cylindrical parts set by interference fit by using 3D regular case field theory in description of contact surfaces.
- 5) To research impact of roughness parameters R_a and S_m of contacting surfaces on capacity of interference and load in contact.
- 6) To perform experimental test of the theory and to assess correspondence between the theory and praxes. To compare interference obtained in the experiment with the calculated one by the developed method of engineering calculations for mating interference fit and to provide conclusions.

Methods of research

- 1) For defining of tensions and deformations of pressed parts, system of computerized designing – program Solidworks Simulation Premium 2010 (method of final elements) – was applied.
- 2) In the experiment, for defining of parameters of micro-topographic surface roughness, Taylor Hobson surface measurement device Taylor Hobson Form Talysurf Intra 50 was applied, which allows viewing of surface roughness as 3D model. Obtained data were processed in program TalyMap Expert.
- 3) In the experiment, pressing of details was performed with 4 T hydraulic press. Experiment of mating durability was performed after assembly for about 24 hours on electromechanical equipment ZwickZ100 designed for testing of static load of details with maximal load up to 100 kN.

Scientific innovation of the paper

Researches of assembly processes of cylindrical parts set by interference fit resulted in defining of admissible failure on mutual layout of details axes in position of assembly, which provides choice of basing schema needed for accuracy and choice of method for reaching of assembly accuracy.

The author has developed mathematical model for defining of durability of contact of cylindrical details set by interference that provides possibility to determine the admissible external force, which in praxes is mainly connection-oriented eccentrically its axes. Defining of tensions and deformation of contact of cylindrical details allows to effectuate research of parameters characterizing the contact and to forecast the servicing period of the connection already on the stage of designing.

Model of cylindrical parts set by interference fit was developed by using 3D regular case field theory in description of surface. It was defined that from standardized parameters of surface roughness, value of interference and pressure of contact is affected by R_a and S_m .

Basing on 3D contact model, new method of engineering calculations for cylindrical parts set by interference fit was elaborated. The method includes proportion of surface roughness parameters R_a and S_m . It provides the possibility to obtain more accurate and more realistic calculation results in comparison to method developed by S. P. Timoshenko.

The elaborated method of engineering calculations for cylindrical parts set by interference fit gives option to define approximation of contacting surface of mating details and its changes at contact load depending on surface roughness parameters R_a and S_m .

Obtained results permit looking at the pressed connection contact of cylindrical details set by interference in new aspect. It gives rise for further researches related to cylindrical parts set with interference fit.

Practical application

Results of research of assembly process obtained in the Doctorate Paper and the developed method of engineering calculations for cylindrical parts set by interference fit may be useful for professionals in the field of mechanical engineering manufacture related to elaboration of assembly process technology and designing of equipment in a specific production unit.

The abovementioned method of engineering calculations is developed basing on contact model of 3D regular case field theory of two rough surfaces, which allows viewing of contacting process of pressed connections with interference in a new aspect by defining roughness parameters corresponding to the real surface. Application of elaborated coherences provides more precise defining of capacity needed for pressing and parameters of surface roughness for mating at definite conditions, which is approved by results obtained in the experiment. It is possible to determine the needed proportion of surface roughness parameters R_a and S_m that is not included in the previously-known calculation methods of mating interference fit.

The following theses are set forth for defence

- 1) Defining of admissible failure in assembly position of mutual layout of axes of cylindrical details designed for automatic assembly.
- 2) Research of impact of roughness parameter of contact surfaces of cylindrical details on durability and assembly process of cylindrical parts set by interference for orientation of details in position of assembly.
- 3) Research of parameters characterizing contact of parts set by interference by using 3D regular case field theory of two rough surfaces.
- 4) Method of engineering calculations for cylindrical parts set by interference basing on 3D contact model.

Approbation of the paper

Major statements and results of the Doctorate Paper were reported. Such reports received positive assessments in the following conferences:

- 50. Internationales Wissenschaftliches Kolloquium Masschinenbau von Makro bis Nano, Germany, Ilmenau, 50.IWK, 2005., 19.-23. September;
- 5th International Conference of DAAAM Baltic Industrial Engineering, Estonia, Tallinn, 2006., 20.-22. April;
- MSM2005 Conference of Mechatronic systems and materials, Lithuania, Vilnius, 2005. 20.-23. October;
- RTU 48. International Scientific Conference, Riga, 2007.

Publications

Main results and developments of performed researches were included in 7 published scientific:

- 1) Dreija Z., Sudnieks Fr., Lininsh O. Deformation of parts with thin walls in assembly process// In: Proceedings of the 50.Internationales Wissenschaftliches Kolloquium, ISBN 3-932633-98-9.- Ilmenau, 2005.-September 19-23, 539.-541. p.
- 2) Dreija Z., Lininsh O., Sudnieks Fr., Mozga N. Friction force and stresses analysis for contact of the assembled details// Solid state phenomena, ISSN 1012-0394.-Vilnius, MSM 2005, Volume 113 (2006), 334.-338. p.
- 3) Dreija Z., Lininsh O. Determination of stresses and deformations for the details assembled by interference fit// RTU Scientific publications. Mechanical engineering and Transportation, ISSN 1407-8015.-Riga: RTU, 2005.-Volume 6-Edition 19, 64.-70. p.
- 4) Dreija Z., Lininsh O., Sudnieks Fr. Influence of friction force and stresses on compression joint// In: Proceedings of IIE Annual Conference. - Orlando, Florid, 2006.-27.-32. p. (CD-ROM).
- 5) Dreija Z., Lininsh O. Accuracy guaranteeing of details assembly by interference fit// In: Proceedings of KOD Design, Serbia &Montenegro, ISBN 86-85211-92-1.- 2006.- 97.-101. p.
- 6) Dreija Z., Lininsh O., Mozga N. Design technique for press fit joint assembly// In:Proceedings of the 5thInternational Conference of DAAAM, ISBN 9985-894-92-8.- Tallin, Estonia, 2006.- 117.-121. p.
- 7) Dreija Z., Lininsh O. Strength ensuring of press fit joints// RTU Scientific publications. Mechanical engineering and Transportation, ISSN 1407-8015.-Riga: RTU, 2007.-Volume 6-Edition 22, 63.-68. p.

Volume of the dissertation and description of structure

The Doctorate Work is written in the Latvian language. It consists of introduction, 6 chapters, conclusions, and bibliography with 94 items, 61 figure, and 8 tables. The Doctorate Work contains 124 pages in total.

CONTENT OF DISSERTATION

Introduction

Introduction substantiates the topicality and practical application of the theme of the Doctorate Paper. It formulates aims and tasks as well as statements.

1. REVIEW OF BIBLIOGRAPHY

The first chapter provides review of bibliography, which includes:

- advantages of automatic assembly and analysis of implementation of automatic assembly in manufacturing;
- review of method for development of technological process of automatic assembly;
- peculiarities of assembly of parts with interference fit;
- main tasks to be solved in the research.

Automation of assembly processes increases productivity and, respectively, reduces labour-intensity of assembly. Situation of rising of assembly labour-intensity at fast paces of processing automation is not possible in long-term; or, by considerable expansion of

manufacturing of products, amount of assemblers may increase significantly. In many cases, especially, in assembly of small products, equipment of automatic assembly takes fewer places than machines of assemblers performing the same process manually. The advantage is a considerable increase of quality of assembled products because most of assembly automates can work only if quality details are provided for assembly. Thus, more stable quality of assembled products is provided. Notwithstanding advantages and indicators of productivity increase, assembly processes in comparison to other technological processes are the less automated.

Mainly, theoretical part of automation of the technological process contains issues of safety of effectuation of the assembly technological process and accuracy of mutual orientation of assembly details since the possibility of automation of assembly process as such and its usefulness depends on solving of these issues. Researches of A. Gavrilov, P. Bulovsky, B. Balakshin, B. Korsakov, A. Malov, M. Novikov, A. Rabinovich, K. Muceniaks, Fr. Sudnieks, N. Mozga, and other authors are devoted for solving of these issues.

Method of development of technological process in the automated manufacturing includes the following stages:

- analysis of the product adaptability to manufacture considering the volume of its output and features for automated processing;
- mechanization and automation for all working and auxiliary movements during processing;
- methods for ensuring of accuracy of the assembly product;
- choice of basing schema;
- defining of assembly conditions;
- mutual orientation of detail axes in space.

In the automatic assembly, concept of adaptability of a structure to manufacture covers both structure of complete part or product and structural features of separate details, which define their suitability to the automatic orientation, supply, and placement on the base detail. Simultaneously, issues on adaptability of machines, equipment, and their parts to manufacture, on simplification of the automatic equipment have to be solved. Possibilities to improve the adaptability of a structure to manufacture in assembly have been described in details by A. Gavrilov, I. Pavlov, A. Paknis, V. Ivanov, and V. Smilansky by analysing a considerable amount of device joint structures, where connections are fastened applying different methods. As P. Bulovsky emphasizes, by improving adaptability of structure of assembly elements to manufacture also different indicators of the assembly process improve. A positive example is reduction amount of details in joint (product), which in its turn permits decrease of amount of operations, simplifying of the process, and averting (completely or partially) of additional operations of mechanical processing during assembly. In addition, a technologic structure increases quality of assembly and accuracy of connection.

During elaboration of the research it was stated that the available scientific papers have not researched the condition of automatic assembly of cylindrical parts set by interference fit $\delta_{\Sigma} \leq \varepsilon_{piel}$. sufficiently. Methods for providing of assembly of mutual orientation of axes of cylindrical details in position in automatic equipment are less effective because of reduction of roughness of surface profile of mating details during pressing. Reviewed papers have not considered surface roughness parameters Ra and Sm, which affect the process of assembly significantly.

Method of calculation for fit with interference (S. P. Timoshenko) includes one of surface roughness parameters Ra despite contact of cylindrical details is a dimensional object and it shall be viewed with 3D surface roughness parameters. Therefore, further parts of the Paper are devoted for researches of the technological process of assembly and parameters of contact of assembly details.

Review of bibliography allows formulating of main tasks of the Doctorate Paper mentioned before (see chapter “Aim and tasks of the Paper”).

2. DETAILS BASING AT AUTOMATIC ASSEMBLY

Basing of parts -it is one of the components of the automatic assembly orientation phase. Preparation of basing may be temporary, or between the orientations of the movement, which is a characteristic component of linear, flat or 3-d displacement. In some cases, basing can take place without the guidance. However, the deviations from the overall scheme should be treated as special cases.

Basing in automatic assembly (fig. 2.1) is very similar to the basing of parts in machining, however it has its own specificity. In particular, there are specific ways of basing. In automatic assembly basing can be stationary and non-stationary. In addition, the basing is achieved resulting in an automatic movement, and in most cases without significant parts fixation efforts. In some cases, the parts do not need to fixate, only with the component placement in basing position. Basing also depends on the assembly mode: base details locate in accordance with rigid conditions; component details locate in difference way- depend on flexibility for appropriate orientation.

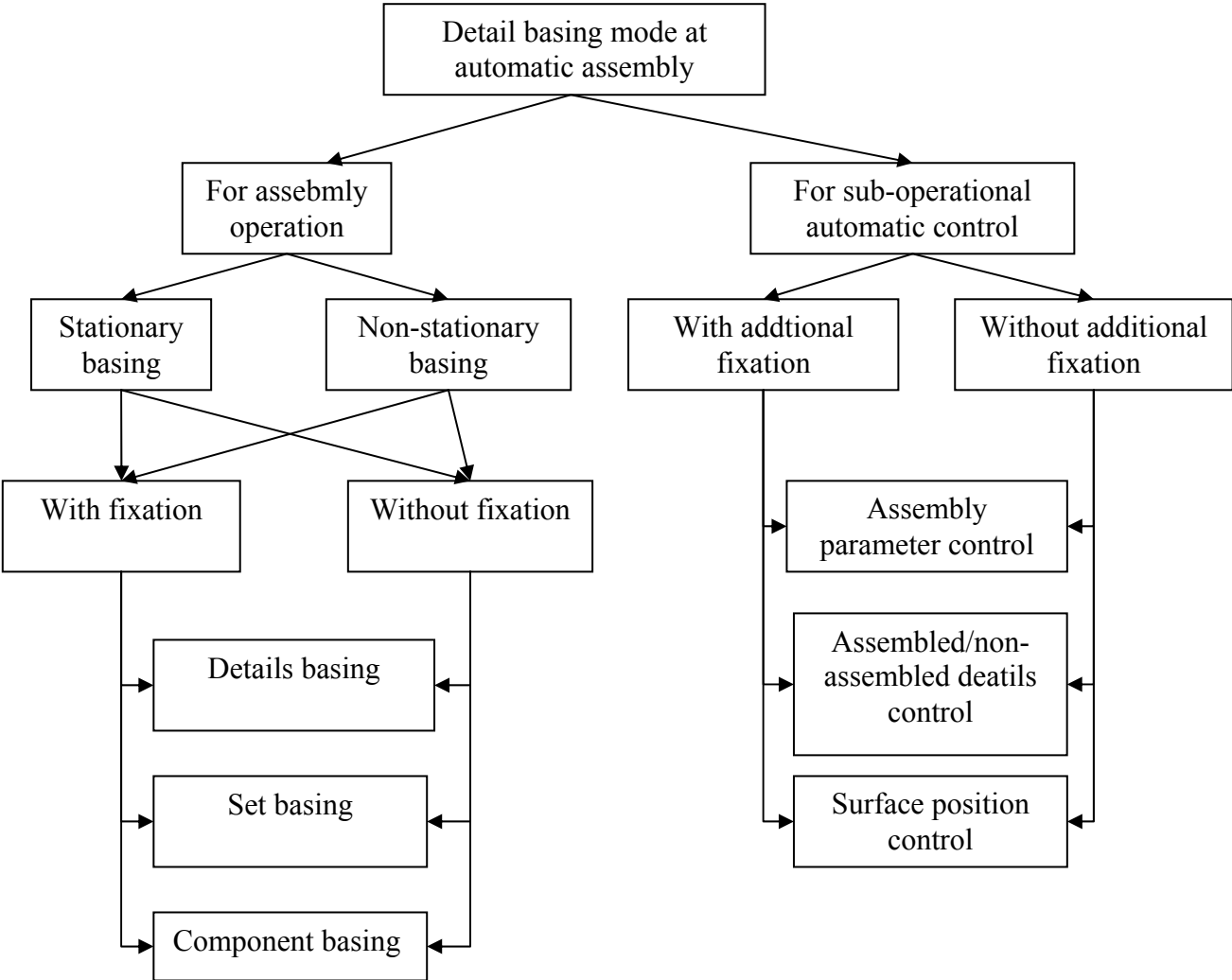

Fig. 2.1. Automatic assembly details basing classification scheme

In the Paper offered suitable basing and fixation techniques for cylindrical details at automated assembly.

3. ACCURACY DETERMINATION OF TECHNOLOGICAL PROCESS FOR AUTOMATIC ASSEMBLY

In the third chapter, as a result of research of assembly processes of cylindrical parts set by interference fit, admissible failure in assembly position of mutual layout of detail axes was defined, which provides choice of basing schema needed for accuracy and choice of method for reaching of connection accuracy. Choice of basing scheme affects accuracy and quality of assembly of the given connection, complexity and function of automatic assembly equipment as well as economic indicators of the established system.

There is developed defining of accuracy of automated assembly processes basing on works of N. Borodachev on determination of allowances and failures of dimensions and cinematic circuits, P. Dunajev on methodology of calculation of dimension circuits as well as works of other authors devoted to definition of accuracy of assembly technological process of separate details. The obtained calculation of accuracy of the process of automatic assembly consists of several stages from defining of summary failure δ_{Σ} of assembly in position of mutual layout of axes of assembly details before their connection and its comparison with the admissible value. Main methods providing reduction of δ_{Σ} are structural and technological methods, for example, accurate regulation of equipment of automatic assembly, increase of accuracy of manufacturing of separate elements of assembly details, and rational choice of basing schemas.

There are obtained expressions for defining of admissible failure of positioning of mutual layout of axes of cylindrical details, where automate in automated assembly together with assembly details will form such dimensional circuit, in which distance between axes of details does not exceed the admissible allowance. A fixed connection is provided if it is possible to assemble spindle and bush with interference $\Delta_{H_{max}}$ (fig. a, b 3.1.).

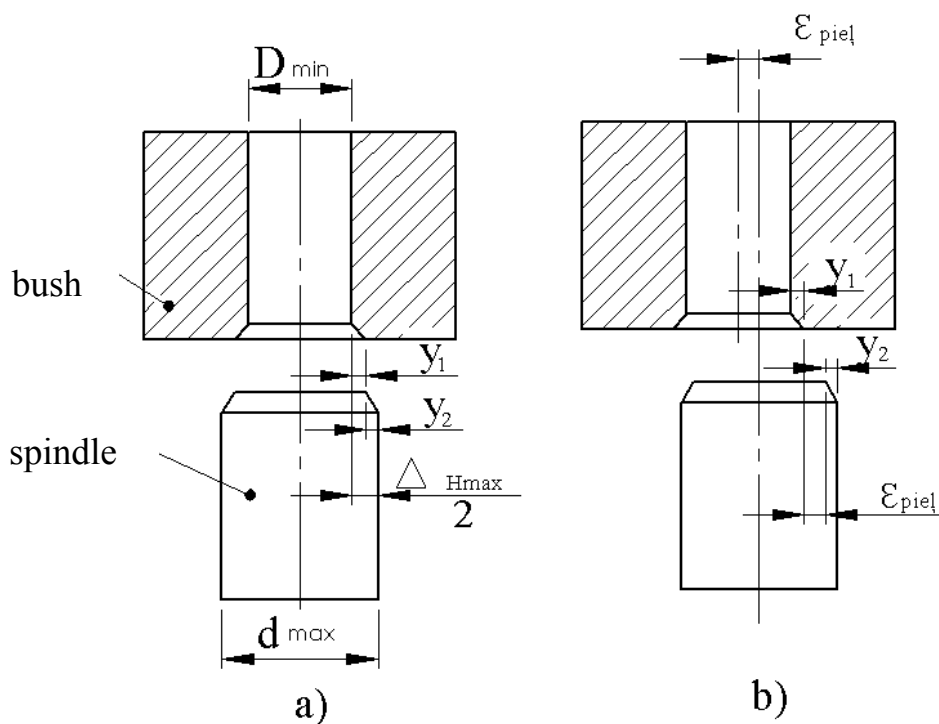

Fig. 3.1. Schema of mutual layout of axes for spindle and bush

It is recommended to form entrance phases in ends of cylindrical assembly details. Minimal dimension of phases y is defined:

$$y_1 + y_2 \geq \frac{\Delta_{H \max}}{2}, \quad (3.1)$$

where: y - phase dimension of spindle and bush; if $y_1 \sim y_2$, than $y_1 + y_2 = 2y$;

$$\Delta_{H \max} = d_{\max} - D_{\min}.$$

Phase y has to be as large as possible. In praxis, most commonly recommended phases for spindle and clutching detail is under angle $30 \div 45^\circ$. However, it is limited by thickness of bush wall and structural demands. Admissible failure ε_{piel} of mutual orientation of axes of bush and spindle, at which assembly is still possible, in this case depends on dimensions of phases and can be calculated:

$$\varepsilon_{piel} \leq 2y - \frac{\Delta_{H \max}}{2}. \quad (3.2)$$

In addition to value of admissible failure of axes layout, the actual value of failure shall be defined, namely, value of failure arisen to assembly object (reason – failure in manufacture) and to the chosen method. Abovementioned researches of mutual layout prove that actual failure of mutual layout of two details in the automatic assembly equals to:

$$\varepsilon_{fakt} = q_{p.b.k.} + q_{k.b.k.} + \Theta_{k.b.k.p.}, \quad (3.3)$$

where: $q_{p.b.k.}$ - failure in basing of drill,

$q_{k.b.k.}$ – failure in basing of spindle detail,

$\Theta_{k.b.k.p.}$ - failure in mutual layout of drill and spindle.

Any couple of details is automatically assembled if $\delta_\Sigma \leq \varepsilon_{piel}$. In case this condition is not followed, most of details are not assembled despite they are usable for assembly of the product. In this case, unassembled details are resent to loading devices providing them with assembly. It requires additional time and impacts total expenses of manufacturing; therefore, it is important to choose a correct basing schema satisfying provisions of assembly already before.

In the Paper, schema of detail contacting by phases is developed (fig. 3.2). In accordance with the schema, axes of assembly details are parallel. In the tangency point A, spindle works on bush, which is freely located on a horizontal plane, with force \bar{S} while related force \bar{G} try to move the bush to the left; consequently, it impacts orienting of bush and spindle. Bush moves to the needed direction if:

$$tg \alpha_1 \geq f_1, \quad (3.4)$$

where: Q and Q_1 – friction forces, accordingly, between support surface and bush and between spindle and bush; f_2 and f_1 – accordingly, friction coefficients Q and Q_1 ; $\alpha_1 > \alpha$.

By finding the force value S , we will obtain:

$$\operatorname{tg} \alpha_2 \geq \frac{f_2 + f_1}{1 - f_2 f_1}, \quad (3.5)$$

It shall be considered that equation (3.5) is true under condition that layout of axes $e=O_1O_2$ does not exceed sum of a_1+a_2 , where a_1 and a_2 - dimensions of phases of bush and spindle.

Such schema may be applied for mutual orientation of short bushes (discs), where risk of turning over under impact of the force \bar{G} excludes. In opposite to it, turning over of bush occurs around point B, by composing equations of moments of these forces in the respective point B, it will be obtained that the bush will not loose its stability if:

$$\frac{b}{h} \geq \frac{\operatorname{tg} \alpha - f_1}{1 + f_1 \operatorname{tg} \alpha} \quad (3.6)$$

where: $b \leq R-r$ - thickness of bush wall.

In case in formula (3.6) we will insert $\alpha=45^\circ$, we will obtain $h \leq \frac{1+f_1}{1-f_1} b$. Consequently, in case when inequity $f_1=0$, has to be $h \leq b=R-r$ or if bush diameter has to exceed its height twice. By assuming value $f_1=1$, we will obtain $h \leq \frac{2+f_2}{f_2} b$. In case values f and f_1 do not exceed 0,3, we

will obtain coherence with failure not more than 20%: $h \leq \frac{1}{f_2} b$.

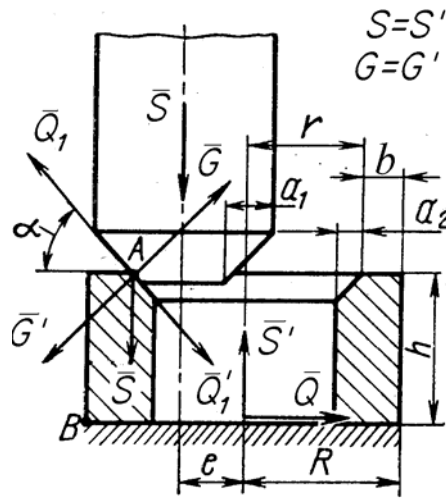

Fig. 3.2. Schema of detail contacting by phases

It is established that force needed for orientation of details in the necessary position depends on friction forming between details in the contacting point. Friction coefficient is mainly defined by surface roughness, which changes in the process of friction. However, in the process of assembly, changes in micro-roughness are not admissible because they decrease further assembly of details and durability of connection. In addition, friction forces between contacting surfaces have to be minimal. Following researches of J. Rudzitis [1, 3], in formula (5.7) we can see that the load between surfaces depends on proportion of Ra/Sm . It means that in contact, the main role is played not by the highness and step of surface roughness separately but by their proportion. In addition, material elasticity constant E and μ shall be considered in calculations.

4. FEATURES OF CYLINDRICAL PARTS SET BY INTERFERENCE FIT INFLUENCE ON ASSEMBLY

In the fourth chapter, impact of pressing force and geometric parameters of details on accurate assembly of details set by interference is researched. As it is proven by the experimental research of the Paper, results obtained in praxes do not always coincide with the calculated ones, which are affected by characteristics of surface roughness and manufacturing failures of assembly details. Thus, establishment of assembly method for control of connection is topical. The fourth part offers pressing system for control of assembly process for automated manufacture. The system controls depth of pressing, force of pressing-in, and its character during the pressing. It is stated that development of process of assembly accuracy providing is related to obtaining and processing of experimental data. During experiments with different parameters of pressing and correlating with curves of pressing force – pressing length and uniformity of products, optimal parameters of pressed connection can be obtained. It is important to control the needed pressing force to guarantee the necessary force limit between surfaces of connected details in the process of assembly. Thus, data on the needed interference are obtained.

Ability of details to bear considerable loads in pressed connections depends on interference. Currently, for increase of connection durability and safety of the equipment operation, calculation of interference fit (S. P. Timoshenko) is performed following the largest admissible interference. It is stated that such method for calculation of mating character is unwelcome; and it is proven by research results obtained during experiment of the Paper. Often, the calculated interference has a big reserve at the given external forces. Thus, it impacts consumption of useless material by choosing geometric parameters of details to provide required durability of the connection.

At present, for calculation of contact pressure by interference, Lama Formula developed by S. P. Timoshenko [2] is used. However, application of this formula asks for many corrections related to different proportions of length and nominal diameter of the connection, uneven tension in length of the detail to be clutched, and manufacture failures. These factors affect the actual value of pressure in contact. It was stated that in current calculations, standard parameters of surface profile roughness R_a and S_m are not considered, which are important values characterizing the surface roughness profile and deformation type of contact of rough surfaces. These parameters define also the choice of the needed type of processing. Entering of more accurate processing technologies into the modern manufacture permits obtaining of details with desirable surface roughness parameters.

5. STRENGTH ENSURING OF CYLINDRICAL PARTS SET BY INTERFERENCE

5.1. Determination of stresses and deformations for the cylindrical parts set by interference

In the fifth chapter, mathematical model for defining of strength of contact of cylindrical details set by interference is developed. There is elaborated strength condition for the admissible external force working on the contact of details. There is obtained expression for defining of the admissible external force, which in praxis is mainly oriented eccentrically to the connection. Usually, cylindrical connections transferring the torsion moment caused by some cross-force F_{sk} (fig. 5.1) are loaded eccentrically. For example, it occurs in transmission elements of rotation movement (gearwheel transmissions).

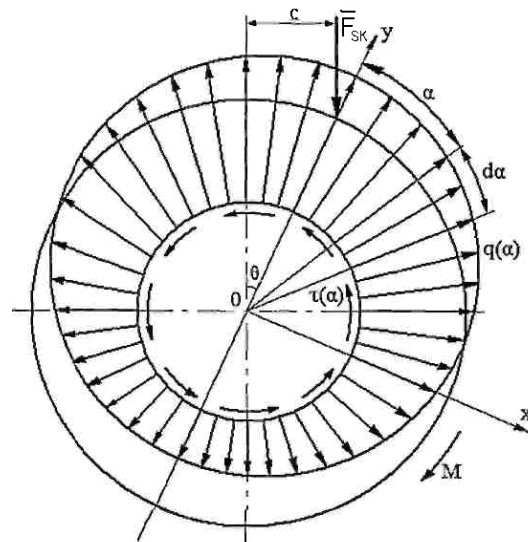

Fig. 5.1 Schema of calculation of external force

There is obtained expression, which defines the admissible value of F_{skp} to eccentric force F_{sk} :

$$F_{skp} = \pi \cdot l \sqrt{1 + f^2} ([p] - p_0), \quad (5.1)$$

where: p_0 – load in contact before application of force F_{sk} ;

$[p]$ -admissible load in contact;

f - friction coefficient.

Defining of tensions and deformations of contact of cylindrical details allows to effectuate research of processes in the contact and to prognosticate service of connection already in the stage of designing. By assistance of program SolidWorks Simulation Premium 2010 (method of final elements), character of tensions and deformations of mating details at perfect conditions, namely, without failures of assembly and processing, is defined (fig. 5.2).

Nevertheless, this method provides the engineer with possibility to experiment with geometric dimensions of details and to choose them considering material, friction coefficient, pressure in contact of surfaces of cylindrical details, interference, and force of pressing.

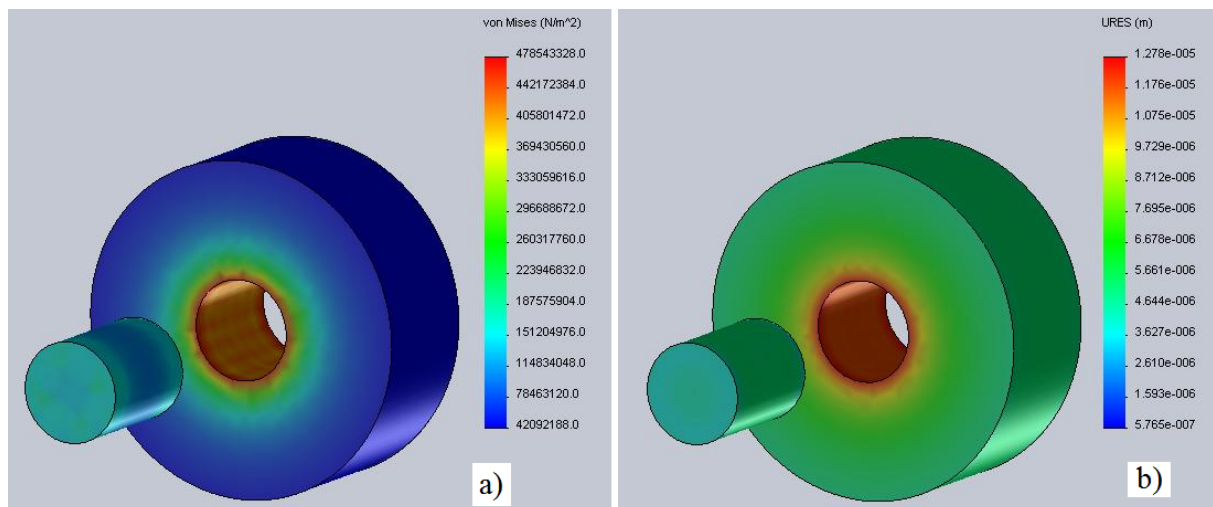

Fig. 5.2. a) changes in summary tension; b) summary changes in dimensions of details

Surface roughness is one of main values characterizing normal functioning of the rigid connection; and this value defines division of normal and tangential tensions in borders of contact area. For defining of impact of such parameters on contacting surfaces of assembly details, contact model of cylindrical details with interference fit by using 3D regular case field theory is elaborated. Each type of mechanical processing and process of surface forming has its own typical topography of surface roughness. Since the pressing process is related with irregular changes in surface roughness of assembly details during the whole length of pressing and in contacting areas, the Paper investigates a model of irregular rough surface corresponding to a regular causality. It was defined that deformation type of connection is affected by standardized parameters of surface roughness Ra and Sm. There was determined the critical approximation of details, at which the elastic contact transfers to the elastic – plastic one.

In order to define, which one of contact surfaces of cylindrical details deforms more, coherence for determination of average value of volume of material deformed during the contact was obtained:

$$E\{V\} = \left\{ \frac{1}{\sqrt{2\pi}} e^{-\frac{1}{2}\gamma^2} - \gamma[1 - \Phi(\gamma)] \right\} \sigma * A_c, \quad (5.2)$$

where: A_c - contour area of contact;

$\gamma = u/\sigma$ -relative level of deformation, until which the rough surface is deformed,

where: u – deformation level subtracted from the average value of roughness;

σ – average quadratic deviation of roughness of contacting surface;

$$\Phi(\gamma) = \frac{1}{\sqrt{2\pi}} \int_{-\infty}^{\gamma} \exp\left(-\frac{t^2}{2}\right) dt - \text{Laplace function.}$$

In majority of cases, in designing of equipment, it is significantly to predict, which one of contacting details is subjected to deformations the most. It provides possibility to choose materials and geometric parameters appropriated for mating details as well as type of processing of contacting surfaces in order to obtain the desirable mate with the needed durability at definite conditions of exploitation.

5.2. Method of engineering calculations for cylindrical parts set by interference fit development by using 3D regular case field theory

By applying the 3D regular case field theory in describing of surfaces, new method of engineering calculations for cylindrical parts set by interference fit was developed. Obtained coherences permit a more accurate determination of force needed for pressing and parameters of surface roughness for connection at definite conditions, which is approved by results acquired during the experiment. It is possible to define the required proportion of surface roughness parameters Ra/Sm characterized by contact load. It was not included in known methods of fit calculation.

Obtained results allow viewing the assembly process of pressed connections of cylindrical details set by interference in a new aspect and giving rise for further researches related to cylindrical parts set by interference fit.

Following previously assumed conditions, there was found the value of force, which works on every of cam peaks of contacting surfaces. Conditions: cam peaks of surface roughness are situated rather densely and even over the whole cylindrical surface; thereby, radial pressure on contact surfaces caused during assembly will be viewed as evenly situated radial load; total deformation of assembly details is elastic and, consequently, subjects to the Lame law; surfaces in areas of actual contact are subjected to elastic-plastic deformations; solidity of a rough surface exceeds the one of an even surface; thus, by performing pressing-in of detail set by interference, peaks of roughness cams deform elastically; there is no impact of external forces on the contact;

mutual influence of peaks is insignificant; there is no deviance in surface form; and nominal contacting surfaces during the whole period of contacting remain mutually parallel.

If heights of cams peaks contacting the even surface are situated in n^{th} levels, the amount belonging to defining of force P_{ij} (fig. 5.3) equals $\sum_{i=1}^K \sum_{j=1}^n P_{ij}$, where K_i - amount of cams and amount of its peaks located in the j^{th} level. P_{ij} - force working on i^{th} group of cams in the j^{th} level.

Average load in contact can be defined in the following way:

$$p_k = \frac{\sum_{i=1}^K \sum_{j=1}^n P_{ij}}{A_a} = \frac{\sum_{i=1}^K \sum_{j=1}^n P_{ij}}{\pi dl}, \quad (5.3)$$

where: A_a – nominal contacting area;

d – nominal dimension of mate;

l – length of contact.

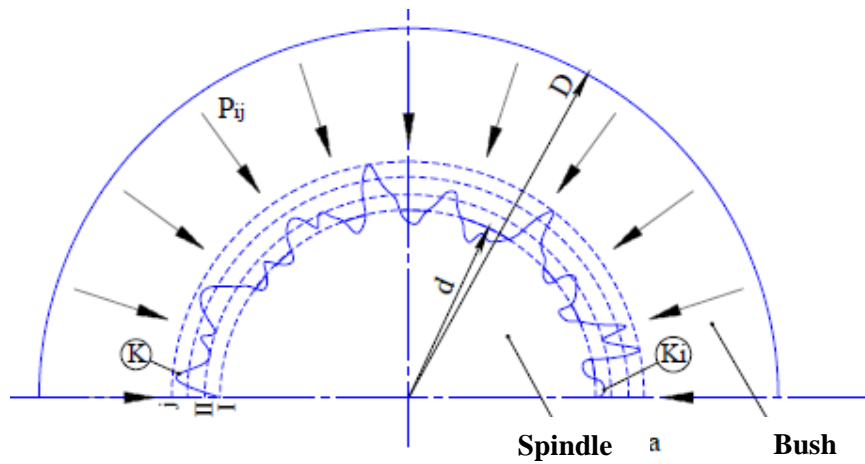

Fig. 5.3. Contact schema of rough (spindle) and even (bush) surfaces of cylindrical surfaces:

I, II, j- contacting levels of cam peaks; K_1, K_2, \dots, K_i - amount of cams located in the j^{th} level; P_{ij} – force working on one i^{th} cam in the j^{th} level

After pressing-in, cams deform under influence of the other surface; consequently, the initial interference will reduce for value S . Presuming that there is no initial deformation of roughness, there is no load on contacting surfaces before their pressing; therefore, we take thickness of roughness level $R_{\max} = 6\sigma$ as point of reference. Consequently, it was obtained that the approximation is:

$$S = (3 - \gamma)\sigma, \quad (5.4)$$

The maximal interference is defined in the following way:

$$\delta_{\max j} = \frac{cd}{A_a} \sum_{i=1}^K \sum_{j=1}^n P_{ij} + 2S, \quad (5.5)$$

where $-c = (C_1 / E_1 + C_2 / E_2) * k$;

where: E_1 and E_2 – elasticity modules of material of assembly details;

C_1 and C_2 – constants of materials;

k – coefficient, which follow changes in contact pressure on surface of the detail longitudinally.

The minimal interference is defined in the following way:

$$\delta_{\min j} = p_s d \times c + 2S, \quad (5.6)$$

where: p_s – load on connection under impact of external forces.

The Doctorate Paper has proven that the relative level of deformation can be defined applying [3] contact theory to an elastic contact, in accordance to which the relative load of the contact can be defined as follows:

$$p_i = \frac{k_q^{el} Ra}{S_m \theta} F(\gamma), \gamma > 1 \quad (5.7)$$

where: k_q^{el} - coefficient that depends on anisotropy of roughness;

$F(\gamma)$ - function that depends on level of deformation;

θ - elasticity constant of material of details.

They are solved in accordance with the following schema: following the given load, parameters of surface roughness, and properties of material, $F(\gamma)$ is defined and then γ is found by tables.

Thus it was obtained that smoothing of micro-roughness depends on proportion of surface roughness parameters Ra/S_m and physical-mechanical properties of material of details.

5.3. Method and example of engineering calculation of interference fit for cylindrical parts

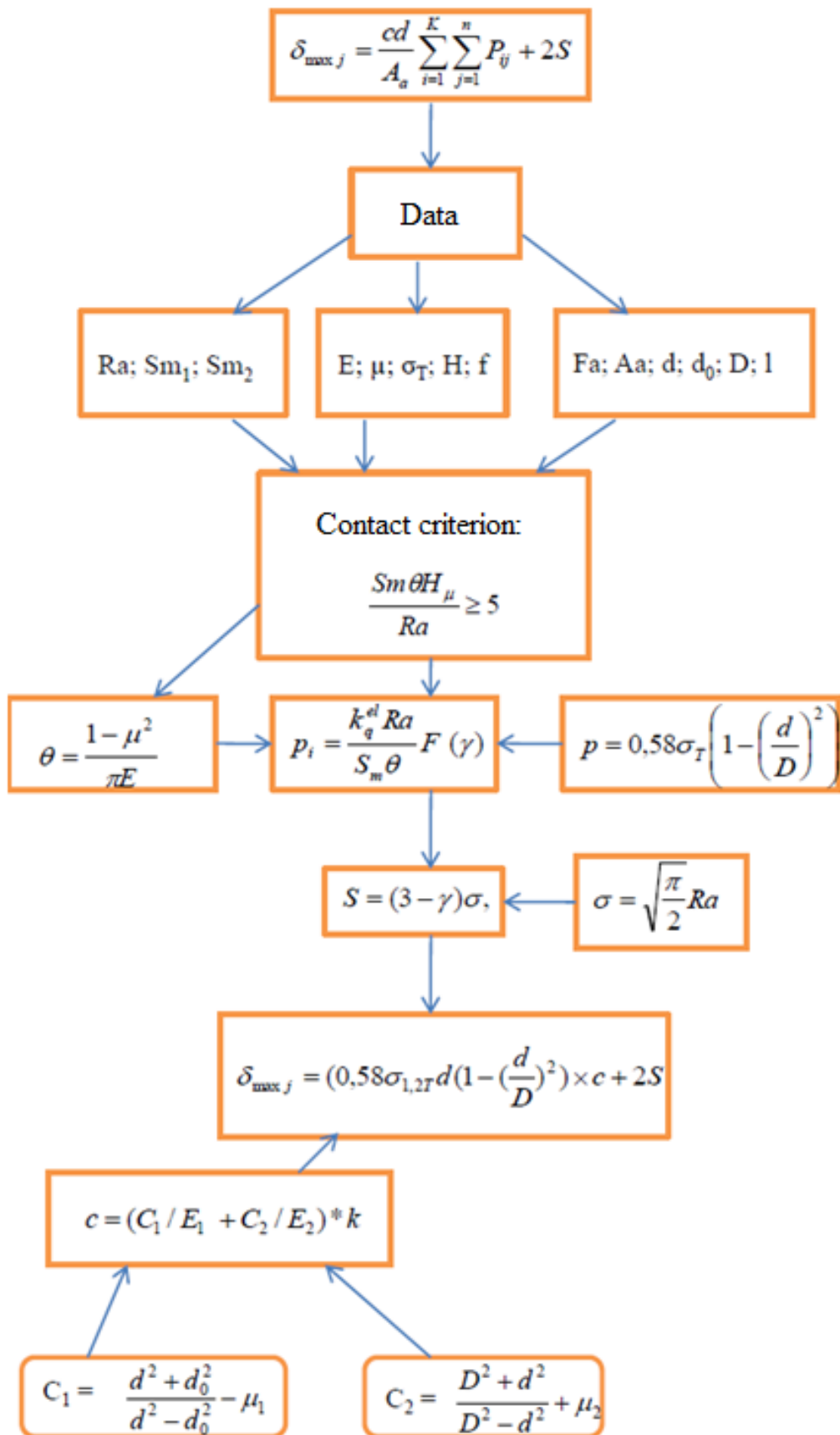

Fig. 5.4. Calculation schema of interference fit

Calculation schema of interference fit given in figure 5.4.

In the Doctorate Paper, method and example of engineering calculations of interference fit is provided. Source data: nominal diameter of connection $d=15$ mm, external diameter of bush $D=50$ mm, length of connection contact $l=20$ mm. spindle and bush have the same material S355J2G3, where: $E=2 \cdot 10^5$ MPa, $\mu=0,3$. By calculations, values of minimal interference following [2] method and the developed method providing reduced value were obtained. By satisfying conditions of connection strength at axial force $F_a=2$ kN, the minimal interference is $\delta_{\min v}=7$ μm [2]; and in accordance with developed method: $\delta_{\min j}=9,5$ μm .

Table No. 5.1

Comparison of engineering calculations for cylindrical parts set with interference fit

| Interference $\delta_{\max j}$, μm | Sm/ Ra, μm | Contact load p_j , MPa | Interference [2] $\delta_{\max v}$, μm | Ra, μm | Contact load p_v , MPa |
|--|-----------------------|--------------------------|--|-------------------|--------------------------|
| 30,2 | 100/1,25 | 186 | 31,3 | 1,25 | 186 |
| 27 | | 169 | 28,6 | | 169 |
| 24 | | 145 | 25 | | 145 |

In the table No. 5.1, results of calculations for cylindrical parts set with interference fit are summarized. At equal loads, interference calculated by the method of S. P. Timoshenko is a little higher. Difference in results is explained by the following:

- 1) By approximation dimensions of contacting surfaces. In accordance with the method of Timoshenko, it is for 1.5 times bigger. In the second case, approximation of surfaces is calculated by (5.4) formula, where relative level of deformation of surface roughness, until which the roughness is deformed, is defined. It depends on pressure in contact and surface roughness parameters Ra and Sm as well as material properties E and μ ;
- 2) In the developed method for calculation of interference fit, surface roughness proportion Ra/Sm is included, which was not considered in the method of S. P. Timoshenko and which is an important value characterising roughness of surface profile and deformation type of contact of rough surfaces. This proportion characterizes also choice of the needed type of processing. As more accurate processing technologies have entered modern manufacture, it permits obtaining of details with desirable parameters of surface roughness. In addition, method of engineering calculation for cylindrical parts set with interference fit offered in the Doctorate Paper allows defining proportion of Ra/Sm needed for definite requirements of mate. Characterizing values of contact: load, approximation of surfaces, and dimension of interference depend not only on a separately taken surface roughness parameter Ra but also on step parameter Sm and their proportion.

The abovementioned confirms that the developed method for calculation of interference provides more accurate and more realistic calculation results in comparison with method [2]. The request for more accurate method of calculation is facilitated by development and progress of mechanical engineering, which demands manufacturing of more and more accurate equipment and long-time resistant parts with high durability.

5.4. Impact of roughness parameters Ra and Sm of contacting surfaces on capacity of interference fit and load in contact research

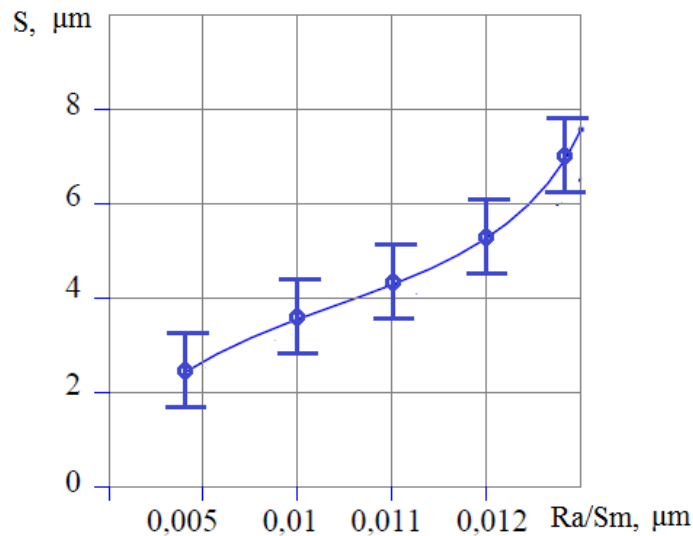

Fig. 5.5. Changes in approximation S depending on proportion of surface roughness parameters Ra/Sm

By increase of Ra/Sm proportion (fig. 5.5), approximation of contacting surfaces of details increases. At the maximal interference 30,2 μm (table No. 5.1), approximation S=8,7 μm was obtained; and at the minimal interference 9,5 μm - S=5,1 μm . Analytically it was defined that by increasing Ra and maintaining value of Sm, approximation S increases while the load decreases respectively. It provides the possibility to view changes in two rough surfaces during contact more completely and to obtain more accurate values of interference depending on forces working on contact because value S is characterized by surface roughness proportion Ra/Sm and load in contact.

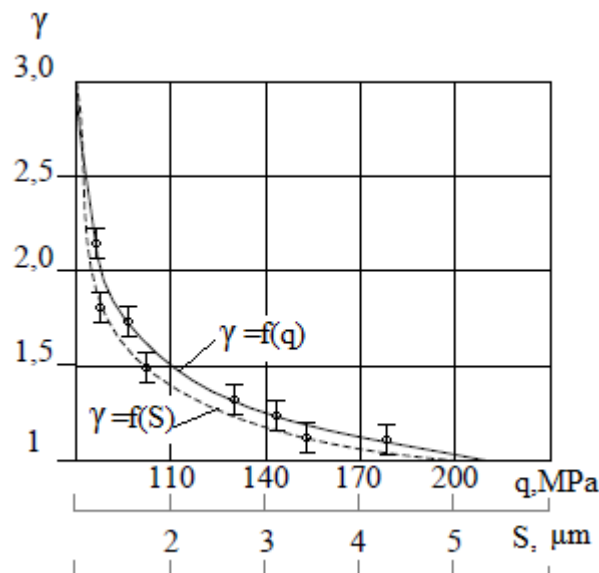

Fig. 5.6. Changes in deformation level of surface roughness depending on load in contact and approximation of surfaces

Figure 5.6 shows changes in deformation level depending on load in contact and approximation of surfaces. Values are obtained in accordance with formulas (5.4) and (5.7). By increase of load, level of deformation reduces. By increase of surface approximation, level of deformation reduces. Similarly to researches of J. Rudzitis [1; 3], higher deformations of surface roughness correspond to lower values of level. By applying the developed formulas in the Doctorate Paper, several coherences between characterizing values of contact were defined; thus, different regularities with real processes of contacting were confirmed.

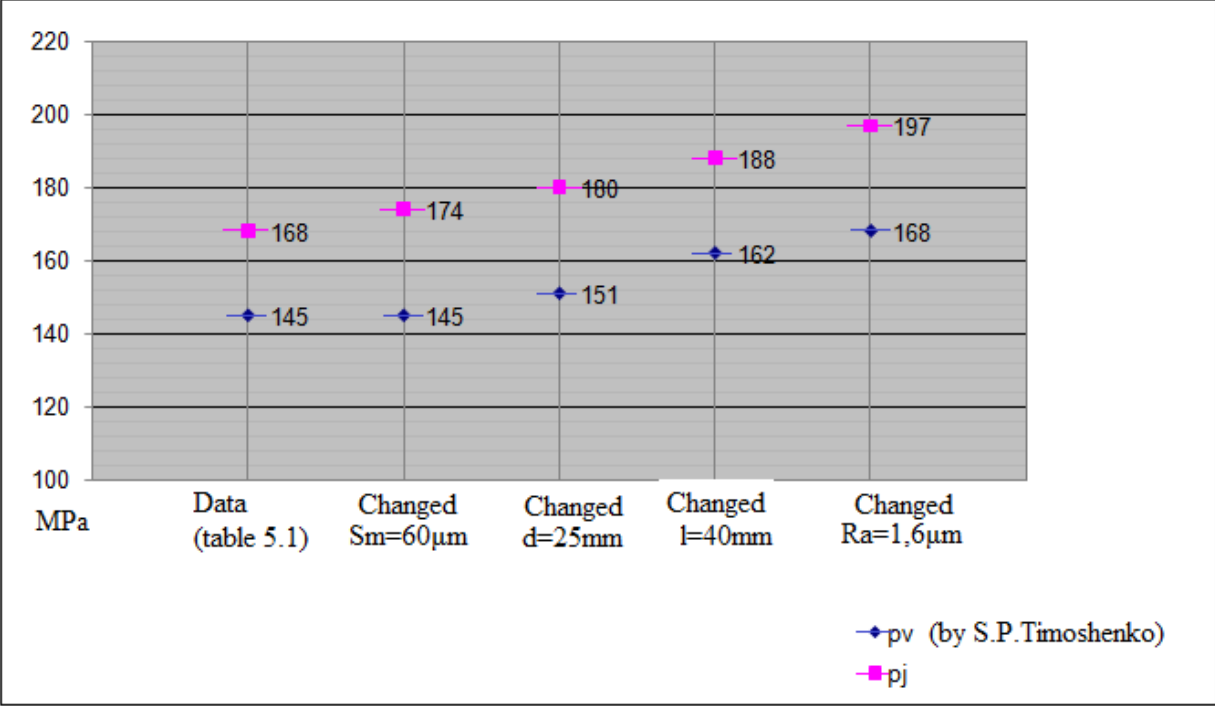

Fig. 5.7. Changes of contact load depending on geometrical and surface roughness parameters

Figure 5.7 shows changes of load in contact depending on the geometrical and surface roughness parameters. By changing the surface step parameter 60 µm (initial 100 µm), contact load, determined by the developed method, will increase. Similar to the J. Rudzitis research [3], decrease of surface roughness step gives increase of contact load. Contact load is increasing if increase Ra but Sm is constant. As has already been researched S. P. Timoshenko method of calculation of interference fit does not include step parameter of surface roughness.

Calculation results obtained following the elaborated method approve higher compatibility with real detail contacting processes than the already known method. The method provides the option to obtain more precise mate with interference and excludes possibilities to choose to high values of interference to provide durability of the connection.

6. EXPERIMENTAL RESEARCH OF ASSEMBLY FEATURES OF CYLINDRICAL PARTS SET BY INTERFERENCE FIT

In the six chapter, the experimental research of changes in geometric dimensions and surface roughness of cylindrical parts set by interference fit in the process of assembly. The aim of the experiment is to test the developed method of engineering calculations for interference fit with results obtained in praxis. For the experiment, 15 samples from different materials and dimensions of details were prepared. For defining parameters of surface roughness profile before assembly and after it, Taylor Hobson surface measurement unit Taylor Hobson Form Talysurf Intra 50 was applied, which allows viewing of surface roughness as a 3D model. For every

experiment, 3 measurements in different section were made; thus providing conformity of measurement track bases. The average result was accepted as the result of measurements.

Figures 6.1 and 6.2 show profiles of experiment sample 1-20B obtained applying this unit.

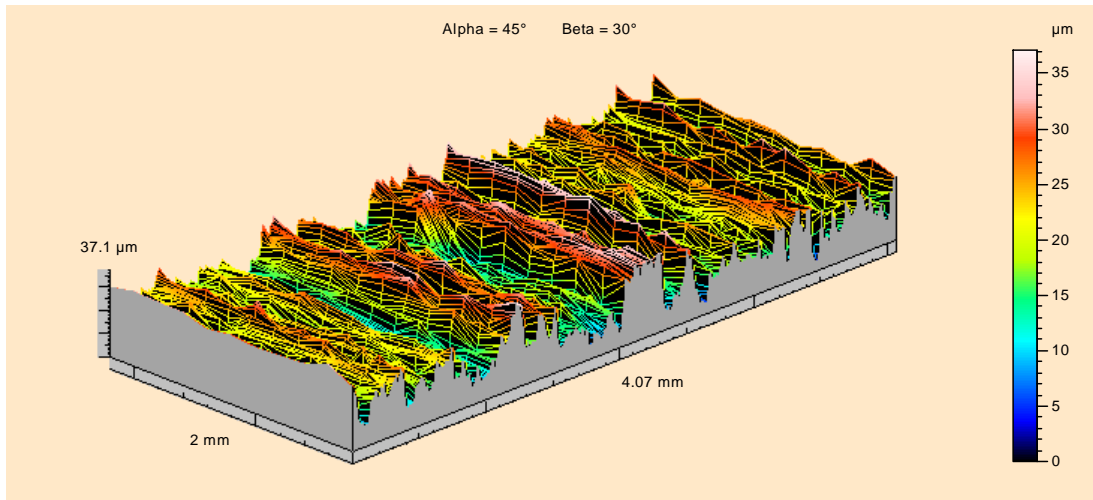

Fig. 6.1. Bend-cleared dimensional figure of surface of sample 1-20B before pressing
(It is turned for 45° around vertical axes and for 30° against axes x and y)

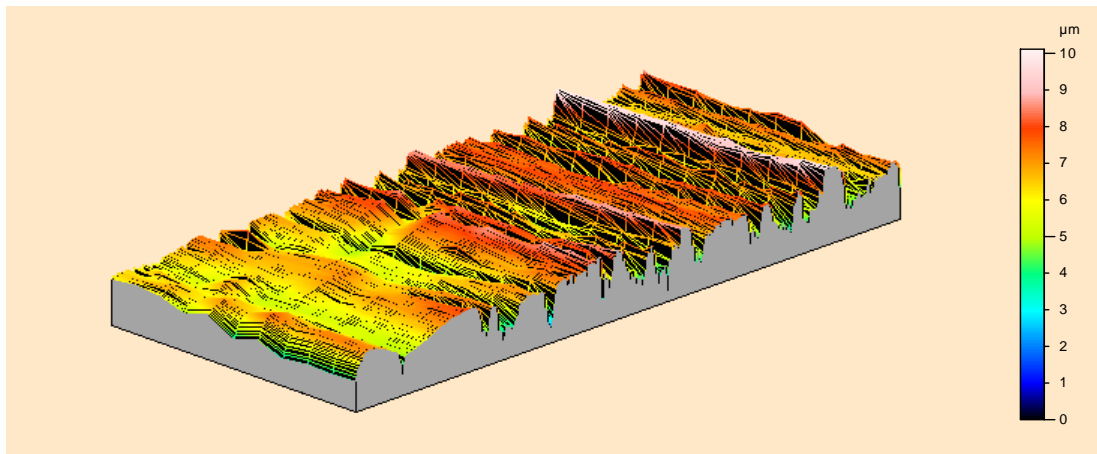

Fig. 6.2. Bend-cleared dimensional figure of surface of sample 1-20B after pressing
(It is turned for 45° around vertical axes and for 30° against axes x and y)

Results of geometric dimensions and surface roughness of cylindrical details with interference obtained in the experiment are summarized in tables 6.1 and 6.2 of the Paper. The specific experimental sample 1-20B shown in figures 6.1 and 6.2 has the initial average arithmetical deviation of surface roughness 2,89 μm while after pressing – 0,98 μm (-67 %). Meanwhile, spindle of the same sample 1-d20 has initial deviation 1,17 μm and after pressing – 0,43 μm (-63 %). Obviously, changes in roughness of bush are bigger. Value of surface roughness smoothing of every sample was impacted by different factors: deviations of detail forms, material, geometric accuracy, and assembly failures.

Experiment of mating durability was performed to 5 parties after assembly for about 24 hours on equipment ZwickZ100 designed for testing of static loads of electromechanical details with maximal load up to 100 kN. In the process of researches, maximal force of pressing P was stated; and it corresponds to the beginning of spindle transfer. Obtained data of the experiment

were used as source data for defining of value of interference by the new method and by the method of S. P. Timoshenko. Afterwards, calculated interferences will be compared with value of interference obtained in praxis (table No. 6.1). Details produced for the experiment conformed by main values of the chosen field of allowances. Therefore, comparing by values of the maximal interference is possible.

Table No. 6.1

Comparison of interference value with calculated one and the one obtained in praxis

| Batch No. | Experimental P, kN | $\delta_{max}, \mu m$ | | |
|-----------|--------------------|-----------------------|--------------------------|----------|
| | | Developed method | Method of S.P.Timashenko | Measured |
| 1. | 15,5 | 35,8 | 39,5 | 34 |
| 2. | 15,8 | 36,4 | 40,1 | 35 |
| 3. | 15,9 | 37,5 | 41,3 | 36 |
| 4. | 16,1 | 38,2 | 41,9 | 37 |
| 5. | 16,5 | 38,5 | 42 | 37,5 |

Friction coefficient in connections with interference reduces by increase of pressure in contact and depends on roughness parameters of contacting surfaces, direction of processing tracks, and materials of details. Currently, there are no such mathematic expressions, which include impact of abovementioned factors on the friction coefficient. These conditions exclude possibility to prognosticate the value of the friction coefficient and to choose combination of such connection parameters, which provide the needed durability of the connection. It makes to use experimentally obtained friction coefficients in calculations of the pressing force. Load in contact is defined by equity $p=P/fA_a$, where it is presumed that the friction coefficient $f=0,08$. Interference calculated by the method of S. P. Timoshenko exceeds the one obtained in experiment for $\sim 16\%$ (table No. 6.1). Meanwhile, interference found following the new method is closer to the value obtained in praxis. Such difference in results can be explained: first, by having the friction coefficient presumed. Second, approximation of micro-roughness exceeds the approximation by the developed method for more than 1.5 times.

Data in the table No. 6.1 certify a better conformity of the new method to the praxis

CONCLUSIONS

In the Doctorate Paper “**Research of technological process for assembly of cylindrical parts set by interference fit**”, the following results were obtained:

- 1) After review of bibliography, it was stated that scientific papers available during the period of elaboration of the research have not researched the condition of automatic assembly of cylindrical parts set by interference fit $\delta_{\Sigma} \leq \varepsilon_{piel}$. sufficiently. Methods for providing of assembly of mutual orientation of axes of cylindrical details in position in automatic equipment are less effective because of reduction of roughness of surface profile of mating details during pressing. Reviewed papers have not considered surface roughness parameters Ra and Sm, which affect the process of assembly significantly.
- 2) As a result of research of assembly processes of cylindrical parts set by interference fit, admissible failure in assembly position of mutual layout of detail axes was defined,

which provides choice of basing schema needed for accuracy and choice of method for reaching of connection accuracy. Choice of basing scheme affects accuracy and quality of assembly of the given connection, complexity and function of automatic assembly equipment as well as economic indicators of the established system. The Doctorate Paper offers the most appropriated methods for basing and fixating of cylindrical details in automated assembly lines.

- 3) It was stated that the assembly process is mainly impacted by two surface roughness parameters R_a and S_m by orienting details in position of assembly.

It was defined that values characterizing mating contact of cylindrical details (load, approximation of surfaces, and value of interference) do not depend only on separately taken parameters of surface roughness R_a and step S_m but also on proportion of R_a/S_m . There is developed a contact 3D model of cylindrical parts set by interference by using 3D regular case field theory in description of surfaces.

It was stated that method of interference fit calculation (S. P. Timoshenko) is not precise considering that cylindrical details are a dimensional object; therefore, profile roughness parameters corresponding to real surfaces shall be defined. One parameter R_a is not enough for characterization of surface roughness. Current calculations have not considered proportion of parameters of surface roughness profile R_a/S_m , which is an important value characterizing surface roughness profile and defining deformation type of contact of rough surfaces.

- 4) There is developed a mathematical model for defining of durability of cylindrical detail contact set by interference for the admissible external cross-force, under impact of which the connection is mainly loaded eccentrically in praxis. There are obtained expressions of durability condition depending on the admissible external force working on the contact of details. It permits effectuation of researches of processes in the contact and prognostication of connection services already in the stage of its designing.

- 5) There is elaborated a new method of engineering calculations for cylindrical parts set by interference fit by using 3D regular case field theory in description of surfaces, which provides possibility to define the force needed for pressing and parameters of surface roughness for mate at definite conditions more accurately; and it was approved by results obtained in the experiment. It is possible to determine the needed proportion of surface roughness parameters R_a and S_m , which is not included in previously known calculation methods with mating character (fit).

- 6) The developed method of engineering calculations for cylindrical parts set by interference fit allows defining changes in approximation value of contacting surfaces of mating details at load in contact depending on proportion of surface roughness parameters R_a/S_m .

Analytically were defined changes in interference value, contact pressure, and approximation of contact surfaces depending on proportion of surface roughness parameter R_a/S_m . In the Doctorate Paper, coherences between values characterizing contact were obtained by applying developed formulas; such coherences approve regularities with real processes of contacting. Similarly to researches of J. Rudzitis [3], load on detail increases due reduction of surface roughness step. Increasing R_a and maintaining S_m value, pressure in contact increases. By increase of load, deformation level of surface roughness decreases. By increase of approximation of surface roughness, level deformation reduces. Higher deformations of surface roughness correspond to lower values of level.

- 7) There was made an experiment with aim to compare the interference obtained in the experiment with the calculated one, by the developed method of engineering calculations for cylindrical parts set by interference fit; and, conclusions were provided. For measurements of roughness of contact surfaces, surface measurement unit Taylor Hobson Form Talysurf Intra 50 was applied.

For checking of mate durability, electromagnetic unit ZwickZ100 for testing of static load of details was used. It was proven that results of the experiment have a better compatibility to the developed method in comparison to the method of S. P. Timoshenko, which gives smaller values of durability of details. Interference calculated by the method of S. P. Timoshenko is in average for ~ 16 % higher than the one obtained in the experiment. Meanwhile, interference found by the developed method conforms to value obtained in the praxis better. Data obtained in the experiment attest that for more precise results of calculation, proportion of surface roughness parameters Ra and Sm shall be considered. Values characterizing contact: load, approximation of surfaces, and interference depend not only on a separately taken surface roughness parameter Ra but also from step parameter Sm and their proportion.

BIBLIOGRAPHY

1. Rudzitis J. *Surface roughness topography investigations// VIIth Int. Oberflächen Kolloquium Technical University of Chemnitz.-Chemnitz: TU Chemnitz, 1992.-65.-70. p.*
2. Timoshenko S. P., Goodier J. N. *Theory of Elasticity.- New York: McGraw-Hill, 1970.-50 p.*
3. Рудзитис Я. *Микрогеометрия и контактное взаимодействие поверхностей. – Рига: Зинатне, 1975. – 216 с.*