

**ASSESSMENT OF OPERATING A SMALL-SCALE CHP PLANT WITH DIFFERENT
INSTALLED HEAT CAPACITIES**

**MAZAS JAUDAS KOĢENERĀCIJAS STACIJAS AR ATŠĶIRĪGU UZSTĀDĪTO
SILTUMA JAUDU DARBĪBAS ANALĪZE**

Dagnija Blumberga, Professor, Dr.Hab.Sc.Ing.

Riga Technical University, Institute of Energy Systems and Environment

Address: Kronvalda Boulevard 1, LV1010, Riga, Latvia

Phone: 371+7089908, Fax: 371+7089923

e-mail: dagnija@btv.lv

Ivars Veidenbergs, Professor, Dr.Hab.Sc.Ing.

Riga Technical University, Institute of Energy Systems and Environment

Address: Kronvalda Boulevard 1, LV1010, Riga, Latvia

Phone: 371+7089908, Fax: 371+7089923

e-mail: ivars@eef.rtu.lv

Anna Vološčuka, Mg. Sc.Ing., PhD student

Riga Technical University, Institute of Energy Systems and Environment

Address: Kronvalda Boulevard 1, LV1010, Riga, Latvia

Phone: 371+7089923, Fax: 371+7089923

e-mail: anna@eef.rtu.lv

Keywords: *CHP, load timeline, small scale cogeneration*

Introduction

Physical processes, which can be described as synchronous production of major energy types, determine the operation of a CHP plant like any other technical system. Regularities and quantitative results acquired during the process of research form the basis for new system development.

But in the case of real equipment, process implementation is not independent, but is limited by technical, economical, environmental and legislative conditions. These conditions include legislative requirements for efficiency factor coverage, minimal operation time per year, primary resource savings compared to the separate generation of heat and electricity. Therefore, research and assessment of real equipment is connected with process research and evaluation, taking into account the aforementioned restrictions.

Research Methods and Models

The aim of the analysis is to clarify current plant parameters and the possibilities of increasing them, and to develop a methodology for assessment of real plant operation on this basis.

A small scale energy source which has a cogeneration plant integrated in its technological scheme is analysed in this paper [1]. A small capacity gas engine is used for cogeneration. The technological scheme of energy sources is depicted in Figure 1.

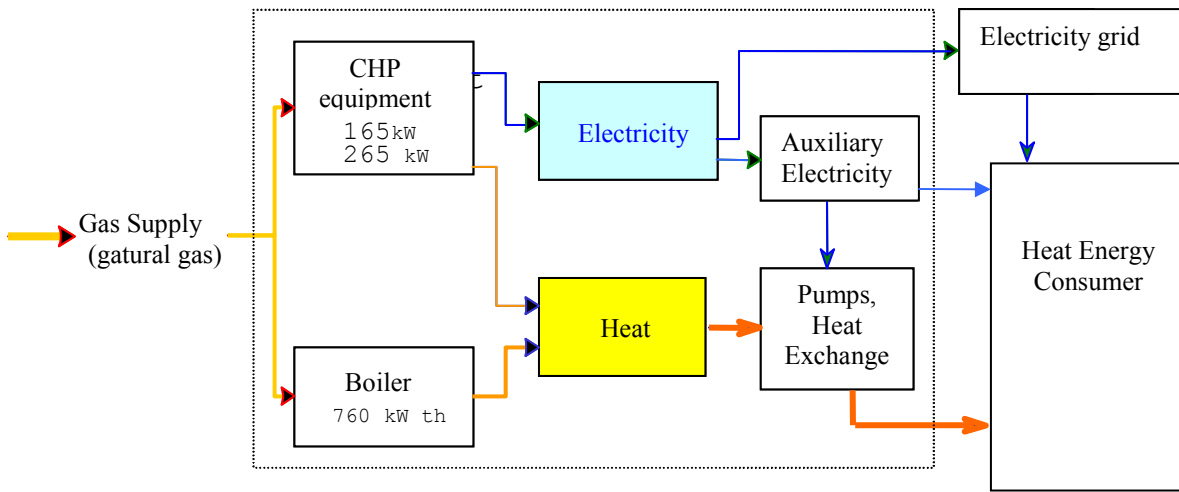

Figure 1. Technological scheme of energy source

Cogeneration equipment is installed in the heat supply system’s boiler house and operates together with a hot water boiler. Heat energy is utilized to cover heat load and hot water load. The CHP plant is connected to the grid and it is possible to supply energy to consumers or to grid. A grid connection allows plant operation with maximal electrical load. Heat consumption defines electrical load. The choice of cogeneration equipment is based on heat supply system heat load, which is determined by heating space, hot water load and heating losses during heat supply. The load timeline of heat consumer is seen in Figure 2.

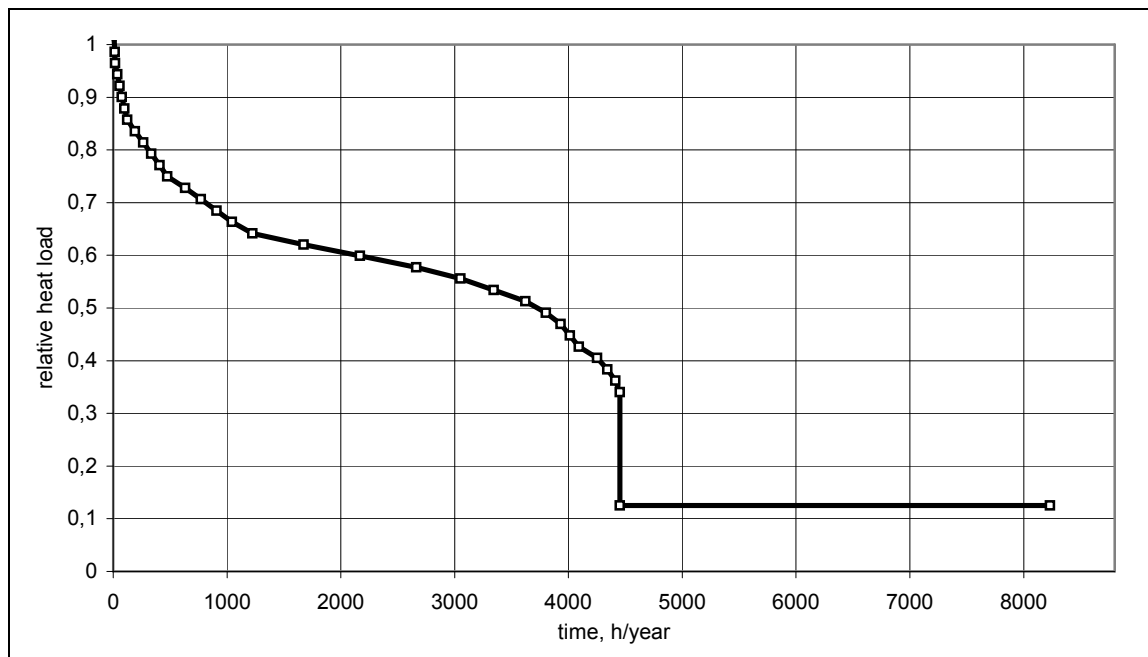

Figure 2. Load timeline of heat consumer

The load timeline of a heat consumer is shown as relative or rationed heat load changes during a year. Relative heat load is calculated with the following equation:

$$r = Q / Q_{\max}, \quad (1)$$

where

- r - relative heat load;
- Q - rationed heat load, MW;
- Q_{max} - maximal heat load, MW (in this case, 1.05 MW).

Various criteria are used for research:

The first criterion is CHP working hours:

- If conditions define that equipment should work with full capacity 7000 h per year, relative capacity can be installed at 0.12 or 130 kW. This means that equipment is installed for hot water heat load, which is low, but is available all during the year.
- Present CHP equipment heat load is 265 kW, or 0.25 from maximal heat load and it can work approximately 4400 h per year. There is the question, whether the chosen capacity is optimal and what the optimality parameter is.

The second criterion is an indicator of optimal capacity, or optimality parameter. Currently, during the choice of capacity there is the condition that heat energy production in full capacity mode would be maximal [2]. Graphically it can be interpreted as the largest rectangle that can be inscribed into the heat load timeline. It means that the optimality parameter can be calculated by equation (2) and searching for the extremum.

$$o = \frac{Q}{Q_{\max}} \cdot \tau \rightarrow \max, \quad (2)$$

where

- o - optimality parameter;
- τ - time of full capacity usage, h/year.

Results and Discussion

For CHP size modelling calculation of criteria values were carried out by applying equation (2). Criteria changes dependent on relative heat load are shown in Figure 3.

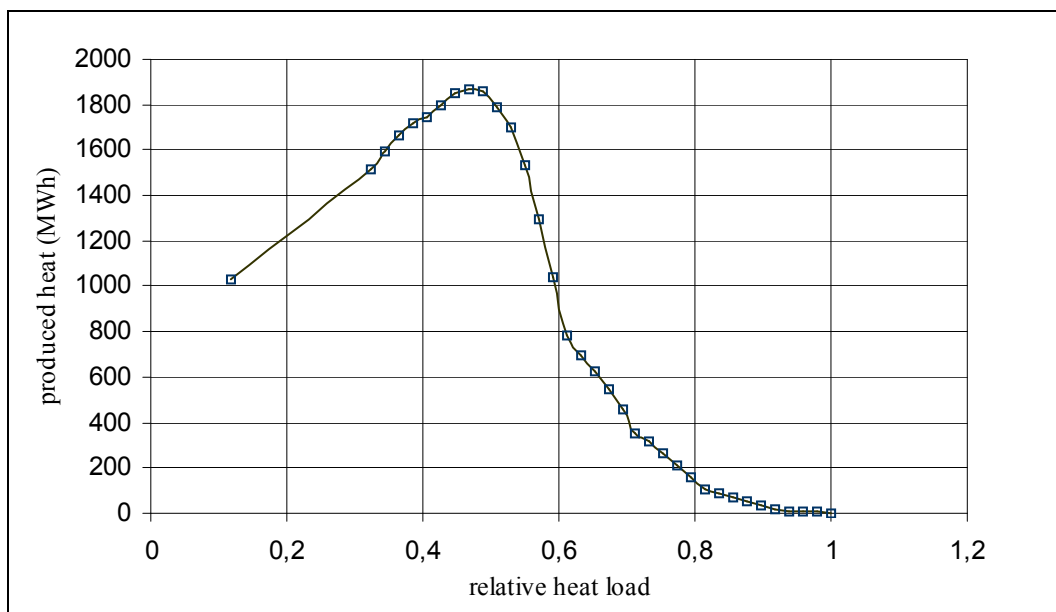

Figure 3. Changes of optimization criteria depending on relative heat load

The data obtained from the calculation indicate that the maximal value is achieved if relative heat load is 0.43-0.47 from maximal heat load (see chart in Figure 3). For the experimental model, optimal heat load is in line with a CHP plant with 0.45-0.49 MW heat capacity. The time when the plant is working at maximal load, as shown in Figure 2, is 4000 h per year.

It means that current plant capacity (265 kW) is not optimal, and in case of larger capacity installation it would be possible to increase heat and electricity production in cogeneration mode. Analysis of two CHP plants operating for a year is carried out for quantitative assessment of the situation modelled before.

The one year everyday CHP measurement data, taken as model input data, are used for assessment:

- CHP produced heat; MWh;
- CHP produced electricity, MWh;
- CHP operating time, h;
- CHP plant total natural gas consumption, m³/day.

Measurement data are used for parameter calculation necessary for further analysis. These parameters are required for the model:

- CHP heat and power capacity, MW;
- CHP total efficiency, heat and electrical efficiency.
- CHP relative load;
- Power to heat ratio value α .

When analysing CHP plant operation, two scenarios were compared:

First scenario: Existing plant with 0.265 MW installed heat capacity and 165 MW electrical capacity.

Second scenario: Alternative plant with 0.475 MW installed heat capacity and 0.295 MW electrical capacity.

During scenario assessment, the following parameters were evaluated:

- CHP heat and power production per year, MWh/year;
- Reduction of primary resource (natural gas) consumption compared to separate energy production, thous. m³/year;
- CO₂ emission reduction compared with separate energy production, t/year.

Various assumptions were made for the alternative plant scenario. It was assumed that:

- Operating time for both plants is equal;
- α and energy efficiency changes in partial load mode are identical.

Heat energy produced by alternative plant is defined on a consumer load basis. If consumer heat capacity demand is higher than or equal to 0.47 MW, the plant is operating at nominal capacity and its efficiency corresponds to 100% heat value.

α determines electricity production. If heat capacity demand is lower than nominal capacity, a plant is operating with partial load, which causes an efficiency value reduction. CHP operation in partial load mode is not analysed in detail. It is important that total efficiency value be not lower than the legally allowed minimal 75% limit. If efficiency is lower, heat should be produced by the boiler.

The dual-scenario CHP interpretation is given in Table 1, where required consumer heat and electricity, produced by CHPs either scenario, are shown in Figure 4.

Table 1

Scenario Interpretation			
Scenario	Heat demand, MWh/year	Heat produced by CHP, MWh/year	Electricity produced by CHP, MWh/year
First scenario	3200	1300	870
Second scenario	3200	2150	1340

A comparison of the results shows, that 1300 MWh/year out of the 3200 MWh/year consumer demand can be produced by the existing plant.

CHP heat production increases to 2150 MWh/year using the alternative scenario.

Electricity production increases from 870 MWh/year up to 1340 MWh/year. The CHP production increase in the alternative scenario is a testament to the fact that it is possible to improve plant operation by setting CHP heat capacity to its optimum.

Monthly amounts of heat and electricity produced by CHP and their relation are shown in Figure 4.

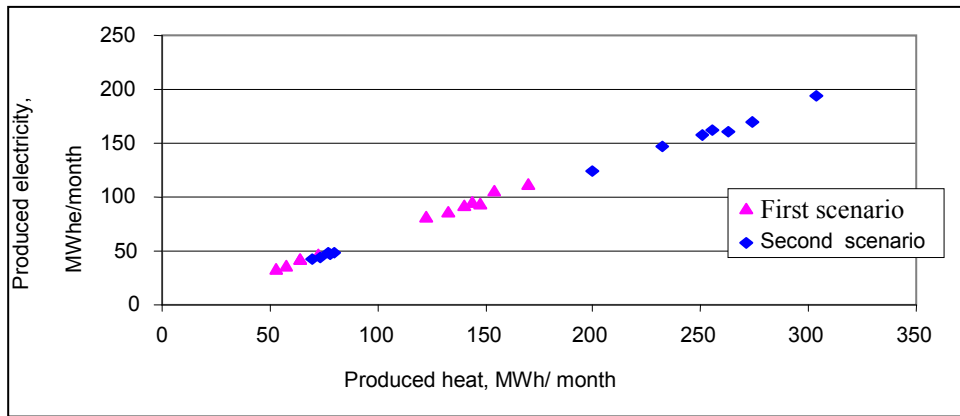

Figure 4. Heat and electricity produced by CHP

Another scenario comparison parameter is the possible primary resources savings comparing to separated heat and electricity production. Equation (3) is used for primary resource percentage savings [3].

$$\delta Q_{PE} = \left(1 - \frac{1}{\frac{r_{el}}{\eta_{el,ats}} + \frac{r_Q}{\eta_{Q,ats}}} \right) * 100, \% , \quad (3)$$

where

r_{el} - CHP electrical efficiency;

r_Q - CHP heat efficiency;

$\eta_{el,ats} = 0.45$ - separated electricity production electrical efficiency;

$\eta_{Q,ats} = 0.9$ - separated heat production heat efficiency.

Fuel consumption reduction, once relative savings are known, is determined by equation

$$Q_{PE} = \sum_{i=1} \cdot \frac{\delta Q_{PEi} \cdot Q_{kur,atsi}}{Q_z^d}, m^3, \quad (4)$$

where

- $Q_{kur,atsi}$ - separated energy production fuel consumption during i days, MWh;
- Q_z^d - fuel lower heat value, MWh/m³;
- i - number of days.

A comparison of fuel savings for analysed scenarios is shown in Figure 5.

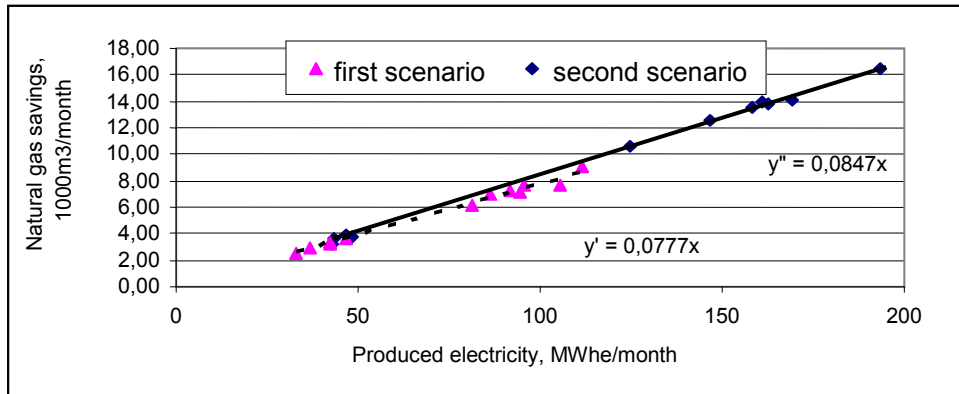

Figure 5. Natural gas savings

It is possible to see that the second scenario line is situated above the first scenario line, and it means that fuel savings compared with the same energy amount for separate production in the alternative scenario is higher than in the existing scenario. It should be mentioned that percentage fuel savings for alternative scenario are lower. It can be explained by longer plant operation in partial load modes. Total fuel consumption is higher because CHP electricity production is higher.

When reducing fuel consumption, influence on climate changes reduces too, because greenhouse gas CO₂ emissions are dependent on fuel consumption. Knowing fuel savings, CO₂ reduction can be calculated with equation (5) [4].

$$\Delta CO_2 = F \cdot Q_{PE} \cdot Q_z^d, t \quad (5)$$

where

F - fuel CO₂ emission factor, tCO₂/MWh.

CO₂ emission reductions compared with separated electricity and heat production are shown on Figure 6.

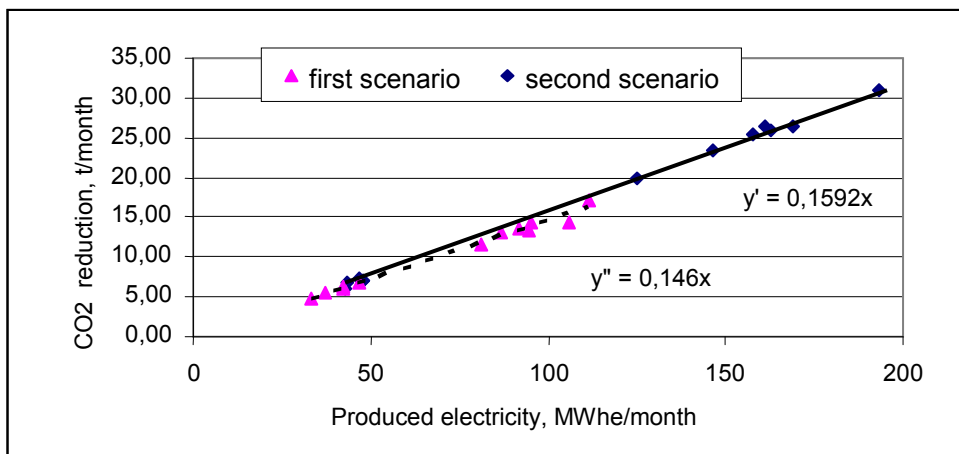

Figure 6. CO₂ emission reduction

It is possible to see that the second scenario line is situated over the first scenario line, as in Figure 5. It means that in the alternative scenario emission reduction is higher, so it is considered the better solution for the climate and the environment.

CHP data assessment shows that for detailed research hourly data are required. It is very important for low loads, which are observed during the summer period. As the summer load analysis shows [1], average daily plant load incompletely characterises its operation, because the plant often operates in on-off mode.

The plant operating assessment shows possibilities for optimization of plant operation and quantitative evaluations of parameter change indicate optimization necessity.

Conclusion

1. The trends and quantitative results acquired during existing equipment operation mode assessment are the basis for system improvement methods. With real, equipment process realization is not free, but limited by economical, technical, environmental and legislative conditions.

These conditions include legislative requirements for efficiency factor coverage, and minimal operation time per year, primary resource savings compared to separate generation of heat and electricity. That is why research and assessment of real equipment is connected with process research and evaluation, taking into account the aforementioned restrictions.

2. Considering existing restrictions and the present heat load of the consumer, the paper simulates plant operation in case of an alternative heat load setting, providing assessments of various figures – heat and electrical power produced in cogeneration, primary resource savings and CO₂ emissions reduction – under the new operating conditions. The character of the changes indicates that the plant's performance improves in the alternative heat load scenario. The amount of heat produced in cogeneration increases by 65%, electric power by 57%, natural gas savings grow by 50% and CO₂ emissions are reduced by 50%.

3. The proposed and approved analysis methodology may be recommended for assessing and enhancing the operation of other plants considering the existing consumer heat load and current restrictions.

References

1. Mineiķis G., Veidenbergs I., Dzene I. Mazas jaudas koģenerācijas staciju darbināšanas pieredze Latvijā // RTU Zinātnisko rakstu krājums „Enerģētika un elektrotehnika”, 4.sēr., 17. sēj., R.: RTU izdevniecība, 2006, 240-246. lpp.
2. K. R. Voorspools, W. D. D'haeseleer. Reinventing hot water? Towards optimal sizing and management of cogeneration: A case study for Belgium. Applied Thermal Engineering. Vol. 26, Issue 16, November 2006, Pages 1972 – 1981
3. D. Blumberga, I. Veidenbergs, A. Vološčuka. Production of electrical and heat energy. Analysis of the efficiency of energy sources. // Latv. J. Phys. Tech. Sci., 2. 2007. 25 –31.
4. M. Blumberga, I. Veidenbergs, D. Blumberga. CO₂ emisiju monitoringa nenoteiktības analīze // Latv. J. Phys. Tech. Sci., 5. 2006. 37 – 45.

Blumberga D., Veidenbergs I., Vološčuka A. Mazas jaudas koģenerācijas stacijas ar atšķirīgu uzstādīto siltuma jaudu darbības analīze.

Rakstā pamatojoties uz siltuma patērētāja slodzes ilguma grafika ir izvēlēta optimāla koģenerācijas siltuma jauda esošai situācijai.

Ievērojot eksistējošos ierobežojumus un patreizējo patērētāja siltuma slodzi, rakstā ir veikta stacijas darbināšanas režīmu simulācija alternatīvas jaudas uzstādīšanas gadījumā, dots rādītāju – koģenerācijā saražotās siltuma un elektroenerģijas, primāro resursu ietaupījuma un CO₂ emisijas samazinājuma novērtējumi jaunos darbināšanas apstākļos. Izmaiņu raksturs liecina, ka alternatīvās jaudas gadījumā salīdzinot ar esošo situāciju stacijas rādītāji uzlabojas. Koģenerācijā izstrādātās siltuma enerģijas apjoms pieaug par 65 %, elektroenerģijas par 57 %, dabas gāzes ietaupījums pieaug par 50 % un CO₂ samazinājums par 50 %. Piedāvāto un aprobēto analīzes metodi var rekomendēt citu staciju darbības izpētē un pilnveidošanā esošās patērētāja siltuma slodzes un pastāvošo ierobežojumu ietvaros.

Blumberga D., Veidenbergs I., Vološčuka A., Assessment of operating a small-scale CHP plant with a different heat capacity setting.

The paper determines the optimum heat load for a given consumer based on the heat consumer's capacity timeline. Considering existing restrictions and the present heat capacity of the consumer, the paper simulates plant operation in case of an alternative heat load setting, provides assessments of various figures – heat and electrical power produced in cogeneration, primary resource savings and CO₂ emissions reduction – under the new operating conditions. The character of the changes indicates that the plant's performance improves in the alternative heat capacity scenario. The amount of heat produced in cogeneration increases by 65%, electric power by 57%, natural gas savings grow by 50% and CO₂ emissions are reduced by 50%. The proposed and approved analysis methodology may be recommended for assessing and enhancing the operation of other plants considering the existing consumer heat load and current restrictions.

Блумберга Д., Вейденбергс И., Волощука А., Анализ когенерационной станции малых мощностей с различными установленными тепловыми мощностями.

В статье основываясь на график длительности тепловой нагрузки потребителя выбрана оптимальная установленная тепловая мощность для когенерационной станции.

Беря во внимание существующие ограничения на тепловую нагрузку потребителя, в статье произведена симуляция режимов работы для случая установки альтернативной мощности, дана оценка показателей-произведённого когенерацией тепла и электричества, экономия первичных ресурсов, сокращение эмиссий CO₂ при новых обстоятельствах. Характер изменений свидетельствует о том, что в случае альтернативной мощности сравнивая с существующей ситуацией показатели улучшатся. Объём произведённой в когенерации тепловой энергии увеличится на 65%, электрической энергии на 57%, экономия природного газа возрастёт на 50% и выбросы CO₂ соответственно уменьшатся также на 50%..