

**BEHAVIOURS OF COMPOSITE CABLES IN THE ROOF****KOMPOZĪTAS VANTIS - PĀRSEGUMĀ**

**Dmitrijs Serdjuks**, Associated professor, Dr.sc.ing.  
Institute of Structural Engineering and Reconstruction  
Riga Technical University,  
Address: Azenes street 16, LV 1048, Latvia  
Phone: + 371 7089284; Fax + 371 70891121  
E-mail: dmitrijs@bf.rtu.lv

**Raymond Ozoliņš**, Associated professor, Dr.sc.ing.  
Institute of Structural Engineering and Reconstruction  
Riga Technical University,  
Address: Azenes street 16, LV 1048, Latvia  
Phone: + 371 7089284; Fax + 371 70891121  
E-mail: rocensk@latnet.lv

**Karlis Rocēns**, Director of Institute of Structural Engineering  
and Reconstruction, Professor, Dr.habil.sc.ing.  
Riga Technical University,  
Address: Azenes street 16, LV 1048, Latvia  
Phone: + 371 7089284; Fax + 371 70891121  
E-mail: rocensk@latnet.lv

*Keywords: composite cables, steel component, saddle-shaped roof*

**Introduction**

High strength materials such as fiber reinforced composite cables (FRCC) and fiber reinforced plastics (FRP) possess potential for their application as constructional materials in combination with the steel. Carbon fiber reinforced plastic (CFRP), glass fiber reinforced plastic (GFRP) and Vectran are examples of such materials. Saddle-shaped cable roof is a type of constructions where such high strength constructional materials could be used on the full scale, because nearly all the load bearing elements are tensioned. However, the most significant disadvantage of the saddle-shaped cable roofs supported by the tensioned cables is the increased compliance. One of the eventual methods to decrease the compliance of the cable roofs is using of the cables with the increased moduli of elasticity. Hybrid composite cable on the base of steel, CFRP, GFRP and Vectran can be considered as an example of such a cable (Figure 1).

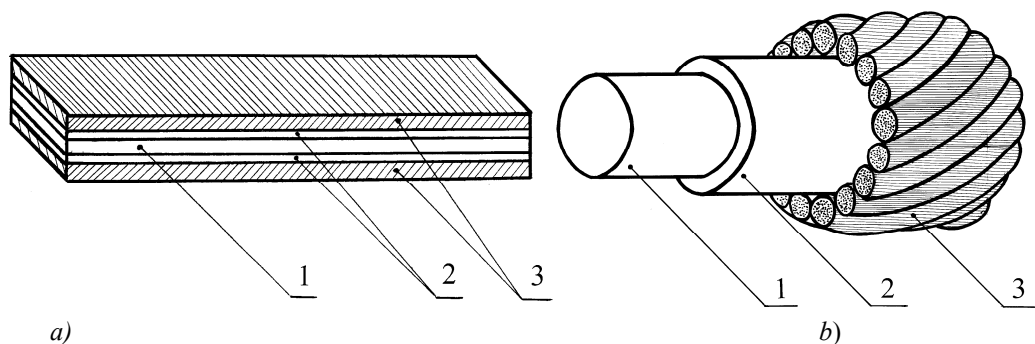

Fig. 1. Hybrid composite elements on the base of steel and FRP; 1 – FRP core; 2 – glue or FRP distributional layer; 3 – steel component.

The purpose of this study is to consider behaviour of hybrid composite cable on the base of steel, CFRP, GFRP, Vectran. Opportunity to decrease the displacements of the composite saddle-shaped cable roof by using of hybrid composite cables for several groups of cables should be investigated.

### Material Combinations for Hybrid Composite Cables

The main directions of the considered hybrid composite cables application are prestressed nets of saddle-shaped roofs. Two types of hybrid composite cables should be investigated.

Thus, the first cable type should obligatorily contain two types of materials: one material with a large limit of strength and the other with an increased ultimate elongation. Third type of materials should be added to transfer perpendicular to the direction of axial force action pressure of the external layer at the surface of the internal one.

Steel wire strands, GFRP (E-glass and epoxy matrix at 60% fiber content), CFRP (AS4/3501-6 graphite fibers and epoxy matrix at 60% fiber content), and Vectran HS 1500 considered as materials for both types of hybrid composite cables. The moduli of elasticity of the materials are equal to  $2 \cdot 10^5$ ,  $0.75 \cdot 10^5$ ,  $1.37 \cdot 10^5$  and  $0.65 \cdot 10^5$  MPa, respectively. Breaking elongations are equal to 10, 2.64, 1.6 and 3.3%, respectively [1–6]. The values of materials characteristics are given in the longitudinal direction X.

Basing on the above mentioned materials properties, two following materials combinations can be considered for the first type of hybrid composite cable: steel, GFRP, CFRP and steel, Vectran, CFRP.

Second type of the cables should be based on the material with the increased ultimate elongation and limit of strength, which is enough to take up tension forces, acting in the stressing cables of the net. Combination of steel, Vectran and GFRP, probably, enables to obtain hybrid composite cables with such properties.

### Peculiarities of behaviours of hybrid composite cables

Generally known dependence of proportional components summing was used for the engineering evaluation of modulus of elasticity of the hybrid composite cable. The dependences are given for the variant of the hybrid composite cable on the base of steel, GFRP and CFRP.

$$E = \Omega_C E_C + (1 - \Omega_C - \Omega_S) E_G + \Omega_S E_S \quad (1)$$

where

$$\Omega_C = \frac{A_C}{A}, \Omega_S = \frac{A_S}{A} \quad (2)$$

$$E_S = \frac{\sum_{i=1}^n m_i A_i E_i \cos \alpha_i [1 - (1 + \nu) p_i \cos^2 \alpha_i]}{A_S} \quad (3)$$

$$A_i = \pi r_0^2 \quad (4)$$

$$p_i = \left(1 - \nu \frac{R_i}{r_i} \sin^2 \alpha_i\right) \times \left[1 - \frac{R_i^2}{4r_i^2} \left(1 - \frac{\nu}{1 + \nu} \sin^2 \alpha_i\right) \sin^2 \alpha_i\right] \quad (5)$$

where:  $E$  – modulus of elasticity of hybrid composite cable;  $A$  – cross-sectional area of hybrid composite cable;  $A_C$ ,  $A_S$  – cross-sectional areas of CFRP and steel components, respectively;  $E_C$ ,  $E_G$ ,  $E_S$  – moduli of elasticity of CFRP, GFRP and steel components, respectively;  $m_i$  – amount of steel wires in the  $i$ -th strand;  $A_i$  – cross-sectional area of the separate steel wire in the  $i$ -th strand;  $r_0$  – radius of separate steel wire;  $E_i$  – modulus of elasticity of steel wire;  $\alpha_i$  – angle of  $i$ -th steel wire strands twisting;  $\nu$  – Poisson's ratio of steel wire;  $R_i$  – radius of  $i$ -th steel wire strand;  $r_i$  – distance between the centres of  $i$ -th steel wire strand and cable.

Modulus of elasticity of the steel component of the hybrid composite cable was evaluated by the method of Cumar and Cochran [7].

The mentioned model for prediction of behaviours of hybrid composite cables was checked by the experiment. Three groups of specimens were tested. The specimens of the first group consist from two steel and one CFRP tapes, which were joined together by the epoxy glue. The specimens of the second and third groups were single CFRP and steel tapes, respectively.

The dimensions of the tapes cross-sections were 50x1.2 mm. The length of the specimens was determined taking into account width of the tape and base of gage in accordance with the ASTM D3039/D3039M-95a. The length of base of the strain-measuring device was equal to 50 mm. The specimens were loaded until the failure by the testing machine with capacity in 300 kN.

The explosive type of failure was stated for all CFRP specimens, which occurs in the middle of the specimen. The results of the test show, that the failure of carbon fibers in hybrid composite specimen occurs in the several sections. The type of failure of hybrid composite specimens was characterizes by the types of failure of separate components. The failure of middle CFRP layer occurs when the strains exceed 1.8 %, what corresponds to the axial force in 204 kN. Than the axial force fall down until 36.6 kN and occurs yielding of steel component until the strains exceed 43%, and steel component also disrupt.

The mean curves for all three groups of specimens together with the analytically obtained curve are shown in Figure 2.

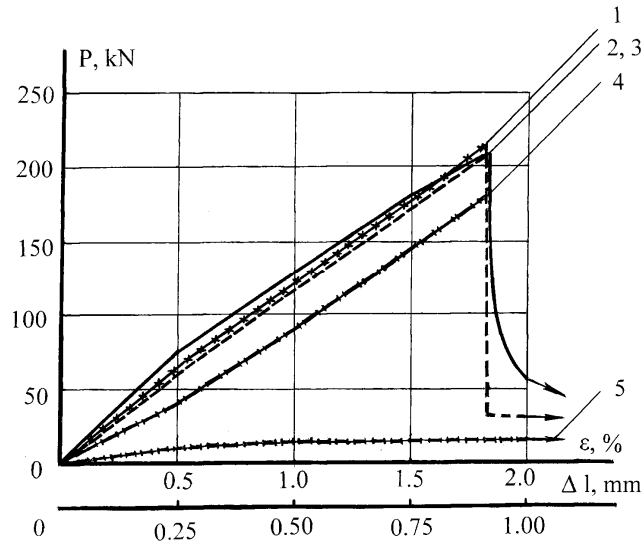

Fig.2. Behaviours of hybrid composite cable: 1 – graph, which was obtained analytically for the composite material on the base of one CFRP tape and two steel tapes with taking into account of two layers of epoxy glue with thickness in 1 mm.; 2 – graph, which was obtained by the experiment for the composite material on the base of one CFRP tape and two steel tapes; 3 – graph, which was obtained analytically for the composite material on the base of one CFRP tape and two steel tapes. Two layers of epoxy glue with thickness in 1 mm were not tacked into account; 4 – graph, which was obtained by the experiment for the CFRP tape; 5 – graph, which was obtained by the experiment for the steel tape. The results were obtained by the strain-measuring device with the length of the base 50 mm.

The comparison of results, which were obtained by the experiment and analytically, indicates that the maximum difference does not exceeds precision of the experiment. So, the model for prediction of behaviours of hybrid composite cables basing on the behaviours of the separate component can be used for coarse evaluations.

The dependence of strain  $\varepsilon$  on the force  $N$ , acting in the cable, was obtained for three variants of composite cables with the area of cross-sections equal to  $0.001 \text{ m}^2$ . Empty space was not taken into account. The dependence was obtained on the base of stress-strain curves of separate components [2–3,6]. The following consumption were considered. The steel wire and GFRP are working in the elastic stage up to the strains, which are equal to 0.95 and 1 %, respectively. Then occurs yielding up to the ultimate strains of 10 and 2.64 %, respectively. The CFRP and Vectran components are working in the elastic stage till the ultimate strains of 1.6 and 3.3 %, respectively. Volume fraction of steel for each variant changes within the limits of 0.1 to 0.7. Volume fractions of GFRP in the two first variants and Vectran in the third variant of hybrid composite cables were constant and equal to 0.2. Angle of steel wire strands twisting was adopted equal to 12 degrees.

The dependence of strain  $\varepsilon$  on the force  $N$ , acting in the cable, for hybrid composite cable on the base of steel, GFRP and CFRP (Figure 3 a)) illustrates, that increase of volume fraction of steel from 0.1 to 0.7 enables the increase by 20.4 % of the value of the force, which can be taken up by the cable. The value of the force corresponds to 0.95 % value of the strain. Modulus of elasticity of the cable grows from  $1.25 \cdot 10^5$  to  $1.57 \cdot 10^5$  MPa at the same time.

The dependence of strain  $\varepsilon$  on the force  $N$ , acting in the cable, for hybrid composite cable on the base of steel, GFRP and Vectran (Figure 3b)) illustrates, that increase of the volume fraction of steel from 0.1 to 0.7, increases by 1.63 times the value of the force, which can be taken up by the cable. Modulus of elasticity of the cable grows from  $0.94 \cdot 10^5$  to  $1.53 \cdot 10^5$  MPa at the same time.

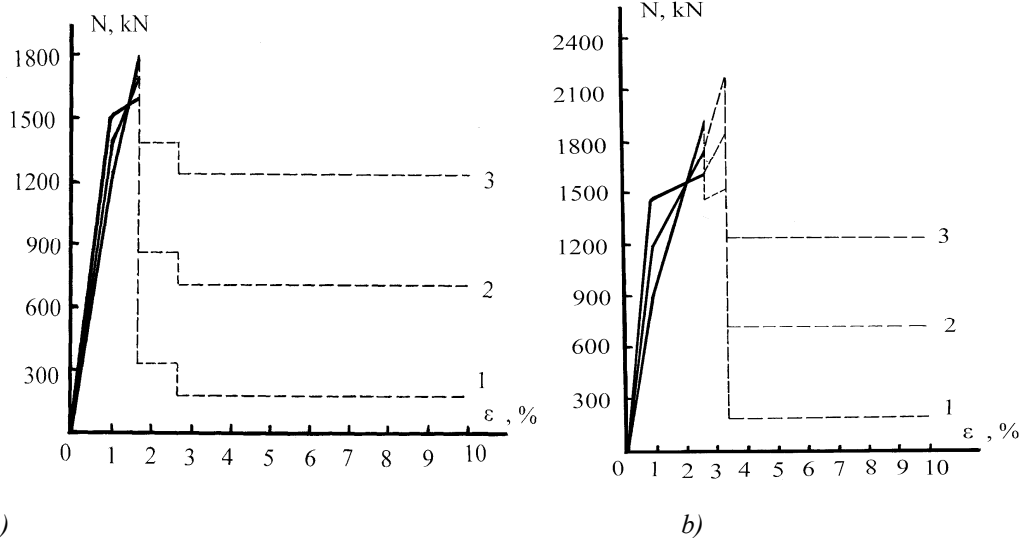

a) b)  
 Fig. 3. Strain of hybrid composite cable a) on the base of steel, GFRP and CFRP and b) on the base of steel, GFRP and Vectran  $\varepsilon$  vs. the force  $N$ , acting in the cable: 1,2,3 – the dependences, which were obtained at volume fractions of steel, equal to 0.1; 0.4; 0.7, respectively; (—) – stage, when all the components of the cables work commonly; (-----) – stage, when some components are disrupted.

The dependence of strain  $\varepsilon$  on the force  $N$ , acting in the cable, for the hybrid composite cable on the base of steel, Vectran and CFRP has a property, which is analogous to the dependences shown in Figure 3 a) and b).

The value of force, which can be taken up by the cable, changes from 1212.5 kN to 1517.8 kN, when the volume fraction of steel changes from 0.1 to 0.7. Modulus of elasticity of the cable grows from  $1.27 \cdot 10^5$  to  $1.6 \cdot 10^5$  MPa at the same time.

Comparison of the dependences of strain  $\varepsilon$  on the force  $N$  for three variants of hybrid composite cables indicates, that maximum strain (2.64%) without any components disruption possesses a variant on the base of steel, GFRP and Vectran. But the value of the force, which can be taken up by the cable, is a minimum for all the variants and equals to 1453.6 kN.

### Example of Application of Composite Materials in Cable Roof

Hybrid composite cable on the base of steel, CFRP, GFRP and Vectran was considered as a material for the tension and main diagonal suspension cables of the saddle shaped cable roof since characteristics of the cables have significant influence on the compliance of the structure [8]. The cable roof was square in plan with dimensions 50x50 m. The initial deflections of the suspension, stressing and tension cables were equal to 20 and 8.6 m, respectively. The distance between the suspension and stressing cables was equal to 1.414 m [8].

The structure was calculated for the basic combination of loads (1.39 kPa) – the dead weight of the structure and the weight of snow – evenly distributed on the horizontal projection of the roof. The design load in the form of point wise forces was applied to the nodes of the cable net.

The maximum vertical displacements of the cable roof were determined by the computer program “ANSYS/ED 5.3”. The existence of two symmetry planes allows us to regard, as a design scheme, a quarter of the cable net of the saddle-shaped cable roof with a compliant supporting contour. Three quarters of the cable roof were replaced by the bonds imposed on its one-quarter part. The cable net was modeled by the finite element of LINK 10 type, with three degree of freedom for each node. Steel cables with an elastic modulus of  $1.3 \cdot 10^5$  MPa

were assumed as a material for the suspension and stressing cables, excluding the main diagonal ones.

The dependences of the maximum vertical displacements of the cable net on the volume fraction of the steel component in the hybrid composite cables were obtained (Figure 4).

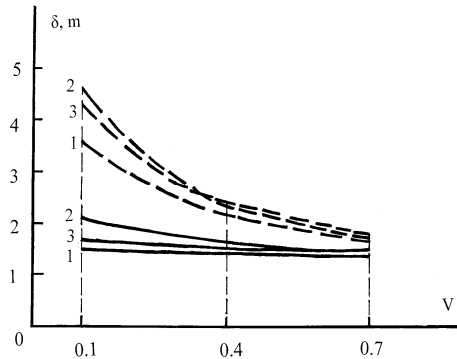

Fig. 4. Dependence of the maximum vertical displacements of the cable roof  $\delta$  on the volume fraction of steel in hybrid composite cables  $V$ : 1 – variant on the base of steel, GFRP and CFRP; 2 – variant on the base of steel, GFRP and Vectran; 3 – variant on the base of steel, Vectran and CFRP; (—) – stage, when all the components of the cables work commonly; (-----) – stage, when all the components, excluding the steel, are disrupted.

In the case, when all the components of the hybrid composite cable work commonly, the increase of volume fraction of the steel from 0.1 to 0.7 causes the decrease of the maximum vertical displacements of the cable roof by 9.31 and 8 % for the variants, when the hybrid composite cable is on the base of steel, GFRP and CFRP, steel, GFRP and Vectran and steel, Vectran and CFRP, respectively.

In the case, when all the components, excluding the steel, are disrupted, the increase of volume fraction of the steel from 0.1 to 0.7 causes decrease of the maximum vertical displacements of the cable roof by 2.21, 2.78 and 2.46 times for the variants, when hybrid composite cable is on the base of steel, GFRP and CFRP, steel, GFRP and Vectran and steel, Vectran and CFRP, respectively.

Maximum vertical displacements of the cable roof are equal to 4.562 m. The value is 1.9 times less, than the distance up to the surface of the ground. But in the case of using of tensioned cladding element on the base of PTFE copolymer foil, reinforced by the Vectran fabric, the maximum vertical displacements are equal to 3.923 m. So, we can suppose that the steel component of hybrid composite cable can prevent failure of the cable roof in emergency, when the strain of CFRP, Vectran and GFRP exceeds the ultimate values and these components are disrupted. The using of CFRP, GFRP and Vectran components enables to decrease the dead weight of the cables by 44 – 47 % when the volume fraction of steel is equal to 0.4 at the same time.

## Conclusions

Hybrid composite cables on the base of steel, GFRP, CFRP and Vectran, which differ by the components and volume fractions, were considered.

It was stated that the increase of volume fraction of the steel from 0.1 to 0.7 causes the decrease of the maximum vertical displacements of the cable roof by 9.31 and 8% for the variants, when the hybrid composite cable is on the base of steel, GFRP and CFRP, steel, GFRP and Vectran and steel, Vectran and CFRP, respectively.

The using of CFRP, GFRP and Vectran components enables to decrease the dead weight of the cables by 44 – 47 % in comparison with the steel ones.

## References

1. Beers D.E. & Ramirez, J.E. Vectran Fibers for Ropes and Cables // In: MTS Conference, Proceedings - Washington, 1990 - p. 662 – 670.
2. Bengtson A. Fatigue Tests with Carbon-Fiber-Reinforced Composite Cable as Nonmetallic Reinforcement in Concrete // Göteborg, 1994 - p.1 – 14.
3. Berger H. Light Structures-Structures of Light: the Art and Engineering of Tensile Architecture, Basel, 2002.
4. Blum R. Material Properties of Coated Fabrics for Textile Architecture. Proceedings of the Symposium "The Design of Membrane and Light Weight Structures", Brussels, 2000- p. 63 – 88.
5. Houtman R. There is no Material Like Membrane Material // In: Tensinet Symposium "Designing Tensile Architecture", Proceedings - Brussels, 2003 - p.178 – 194.
6. Peters S.T. Handbook of composites, London, 1998.
7. Kumar K. & Cochran Ir.I.E. Closed form analysis for elastic deformations of multilayered strands // In: Journal of Applied Mechanics, ASME, 1997 - p.898 – 903.
8. Serdjuks D. & Rocens, K. Hybrid Composite Cable with Steel Component as Structural Element // In: Advanced Steel Construction, an International Journal, Vol. 4, No. 3, - Hong Kong, 2008 – p.184-197.

### **Serdjuks D., Ozoliņš R. un Rocēns K. Kompozītas vantis – pārsegumā.**

*Analizēts hibrīdo kompozīto vanšu darbs un pielietojuma efektivitāte uzspriegtam sedlveida vanšu pārsegumam ar izmēriem 50x50 m plānā.*

*Kompozītās vantis sastāv no tērauda, stiklaplasta, oglekļaplasta, vektāna un atšķiras ar komponentu daudzumu pēc tilpuma.*

*Vanšu deformējamība noteikta analītiski, izmantojot inženieraprēķina metodi. Atsevišķam gadījumam (tērauds un oglekļaplasts) analītiski iegūtie rezultāti salīdzināti ar eksperimentāliem.*

*Aplūkota iespēja samazināt pārvietojumus un pašsvaru sedlveida vanšu pārsegumam ar izmēriem 50x50 m plānā, izmantojot hibrīdas kompozītas vantis gan kā nesošas, gan kā konturvantis.*

### **Serdjuks D., Ozoliņš R. and Rocēns K. Behaviours of composite cables in the roof.**

*Peculiarities of behaviours of hybrid composite cables in saddle-shaped roof were investigated.*

*Hybrid composite cables on the base of steel, GFRP, CFRP and Vectran, which differ by the components and volume fractions, were considered as materials of suspension and contour cables for a prestressed saddle-shaped cable roof with the dimensions 50x50 m. The behaviours of hybrid composite cable were investigated analytically and by experiment. Simplified method for prediction of mechanical properties of hybrid composite cables was suggested and checked by the experiment.*

*Opportunity to decrease the displacements and dead weight of composite saddle-shaped cable roof with the dimensions 50x50 m by using of hybrid composite cables with steel component for suspension and contour cables was investigated.*

### **Сердюк Д., Озолиньш Р. и Роценс К. Работа композитных вант в покрытии.**

*В работе исследовано поведение гибридных композитных вант в седловидном вантовом покрытии.*

*Гибридные композитные ванты на базе стали, стеклопластика. Углепластика и вектрана были рассмотрены в качестве материала несущих и контурных вант предварительно напряженного седловидного вантового покрытия размером в плане 50X50 метров. Гибридные композитные ванты различались объемными фракциями компонент. Работа гибридных композитных вант рассматривалась аналитически и экспериментально. Упрощенный инженерный метод использовался для оценки механических свойств гибридных композитных вант. Точность метода определена экспериментально.*

*Исследована возможность уменьшения перемещений и собственного веса композитного седловидного вантового покрытия размером в плане 50X50 метров путем применения гибридных композитных вант.*

*Гибридные композитные ванты использовались в качестве материалов несущих и контурных вант покрытия.*