

Mechanical Recycling of Compounded Plastic Waste for Material Valorization by Briquetting

Jaana Kers, *Tallinn University of Technology*, Peter Krizan, *Slovak University of Technology in Bratislava*,
Martin Letko, *Slovak University of Technology in Bratislava*

Abstract: In this contribution the study of recycling technology for plastic wastes and material valorization by briquetting technology is described. Various type of wastes (wood, carton, paper, plastic, textile) were processed by two-shaft and single-shaft shredders to obtain the output product 1-2 millimeters, which is suitable for briquetting process. For samples manufacturing the briquetting equipment developed in Slovak University of Technology in Bratislava was used. The briquettes were pressed from 5 different samples of compounded material containing plastic, carton, textile, wood and other type of waste material. Technological test showed that briquetting of the municipal waste the higher pressing temperature and compacting pressure should be applied. For quality evaluation of the manufactured briquettes the density and strength properties were determined. The mechanical strength of briquettes from refuse derived fuels increased after mixing it with wood and paper wastes. The influences of the different parameters (fraction size, moisture content, compacting pressure and temperature) to briquette quality were presented.

Keywords: plastic scrap valorization, plastic recycling, disintegration, briquetting

I INTRODUCTION

Environmental protection and material recycling are important matters today. For renewable energy resources utilization the briquetting technology is used. Biomass based fuels are utilized in many countries [1, 2]. Briquettes are produced not only from biomass, but also from different type of wastes like papermill, plastic and other combustible wastes [3]. Different type of briquetting equipment and its modifications are under development [4]. Alternative fuels like biomass are making breakthrough to energy sector for production of green energy [5]. Currently in Estonia the refuse derived fuels (RDF) fuels (milled plastic packaging waste) are used in rotary cement kiln by blowing the milled compounded plastic particles (25 mm) into the burning chamber. In the future these wastes could be grinded and briquetted for gasification in power stations for production of green energy.

Before the waste briquetting pre-conditioning of the material is necessary. First step is processing of municipal waste by disintegrator mills for the size reduction. Smaller particle size enables to obtain better properties of the product by drying, mixing and briquetting. Mixing of milled plastic waste with other biological materials (wood sawdust, paper, etc.) leads to better briquette pressing as well as greater calorific value. Before briquetting the material moisture content should be reduced by drying process. Lower moisture content improves briquetting process.

Briquetting is the most known and a widely spread technology of materials compacting. The technology uses mechanical and chemical properties of materials to compress them into the compact shape (briquettes) without usage of additives or binders in the high pressure compacting process. Briquetting is mostly used for compacting of biomass (sawdust, wood shavings, bark, straw, cotton, paper, etc.). The biomass undergoes the process of briquetting, while high pressure and a temperature simultaneously act upon the mass, the cellular structures within the material release lignin, which binds individual particles into compact unit - briquette. Briquetting, however, can be also used for compacting of compounded plastic waste or municipal waste etc.

Briquetting is executed by briquetting presses. The material is pressed into the pressing chamber with high compacting pressure and high pressing temperature.

For briquette quality control, the physical parameters, such as density, moisture content and compressive strength, were found to be the best indicators of additive quality [6].

In this contribution the study of recycling technology for plastic wastes and material valorization by briquetting technology is described.

II EXPERIMENTAL

A Size reduction of the wastes

The two-shaft and four-shaft shredders and combination with single shaft shredders are generally used for size reduction of different type of waste material or end of life products. Principle of mechanical size reduction process is very simple. Rotorblades of the one rotor rotate against cutting elements of the second rotor. Cutting elements of rotors are catching material and cut output fraction. Dimensions of material before disintegration are hundreds of millimeters. The size of output fraction after first step of disintegration is tens of millimeters. Productivity of disintegration machines depends on dimensions of machine, rotation velocity, size and shape of input fraction. Productivity could be hundred to thousand kilograms per hour. In the Fig. 1 is principal scheme of two-shaft shredder.

Disintegration in single shaft shredder follows after disintegration in two or four shaft shredders. There is grinding process in the single shaft disintegration machine. Output fraction passes through the screen. Screen is mounted under rotor and it assures homogeneity of output fraction. The size of output product is 1-2 millimeters. This product is suitable for briquetting process. Productivity of single-shaft shredders is from hundreds to thousand kilograms per hour and it depends on, size of openings in screen, cutting wedges on the rotor, rotation velocity etc.

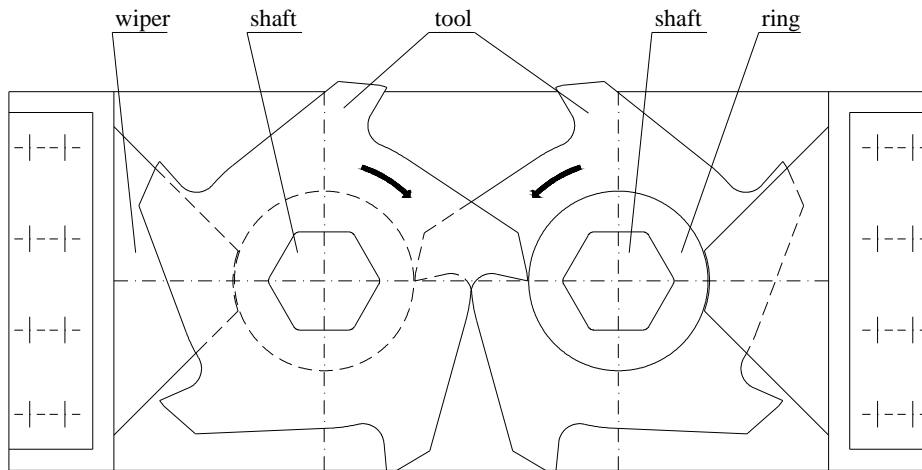

Fig. 1 Principal scheme of two-shaft shredder

B Briquetting equipment

Briquetting is executed by briquetting presses (see Fig.2). On the right picture the circle shows the place where heating equipment should be inserted.

Compacting process of the plastic and municipal waste into the briquette is not as simple as it is in the case of briquetting

of biomass waste, because municipal waste (plastics, textile, etc.) does not contain great amount of biological materials and therefore does not contain lignin – which is natural binder. For briquetting of the municipal waste the higher pressing temperature and compacting pressure should be applied.

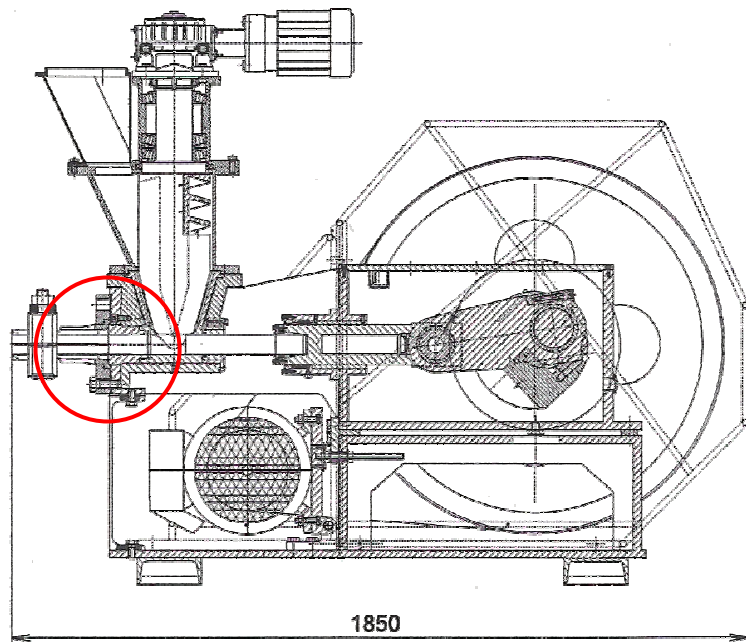

Fig.2 Mechanical (cranked) briquetting press [7]

C Evaluation of briquetting parameters

Density is an important parameter which characterize briquetting process. The higher the density, the higher is the energy/volume ratio. Hence, high-density products are desirable in terms of transportation, storage and handling [6]. The density of biowaste briquettes depends on the density of the original biowaste, the briquetting pressure and, to a certain extent, on the briquetting temperature and time.

The density of the briquette is calculated according to

$$\rho_N = \frac{m_N}{V_N}, \quad (1)$$

where V_N is briquette volume;
 m_N is briquette weight.

III RESULTS AND DISCUSSION

The compression strength of briquettes in cylindrical shape is determined by cleft failure (see Fig. 3). Briquette is placed between round dies of press where it is equally compressed by increasing the compression force till the cleft fracture. For testing only the compacted and intact briquettes should be used. Maximization of the applied force leads to increase of stresses inside briquettes until the specimen failure by cleft. Determined maximum value specifies briquette compression strength. The ratio between maximal applied compression force and briquette length is the indicator of compression strength.

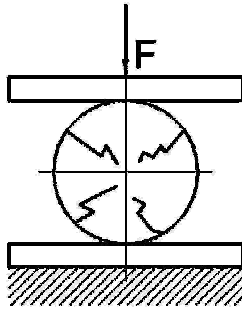

Fig. 3 Testing of briquette compression strength in cleft failure conditions

The compression strength of the briquette is calculated using formula

$$\sigma_{Br} = \frac{F_{max}}{L_N}, \quad (2)$$

where σ_{Br} is briquette strength in cleft-fracture conditions;
 F_{max} is maximal applied force during the test ;
 L_N is briquette length.

A Technological tests with Briquettes

The briquettes were made from various compounded materials. For samples manufacturing the briquetting press (See Fig.1) developed in Slovak University of Technology in Bratislava was used.

Several tests to estimate the influence of compacting pressure to briquette quality were performed.

The results are presented in the Fig. 4. Briquettes from the same type of material (wood sawdust) with same fraction size with same moisture content were experimentally manufactured at same pressing temperature by changing only one parameter - compacting pressure. As it follows from Fig. 4 the briquettes manufactured at lower pressures fall to pieces. Briquettes produced at higher pressures are consistent and compact. The briquettes density is also increasing at higher compacting pressures.

Therefore the wood and paper wastes have to be added to the plastic and municipal waste. These materials contain lignin and help to bind the particles together into the briquette. Lignin acts also as stabilizer of cellulose molecules in cell wall. The more lignin the material contains the more of it can be released to produce briquettes with higher quality. The higher concentration of lignin assures better briquette strength. High pressing temperature is needed also for plastic and municipal waste plasticization. Briquetting presses are mainly manufactured without heating equipment. Therefore it is recommended to attach the heating equipment to the briquetting press for briquetting of plastic and municipal waste (Fig.2). It will increase the quality of the briquette.

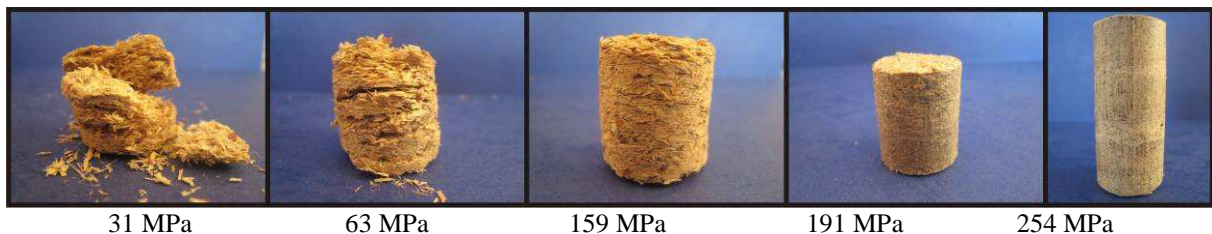

Fig.4 The effect of the compacting pressure to briquette quality [7]

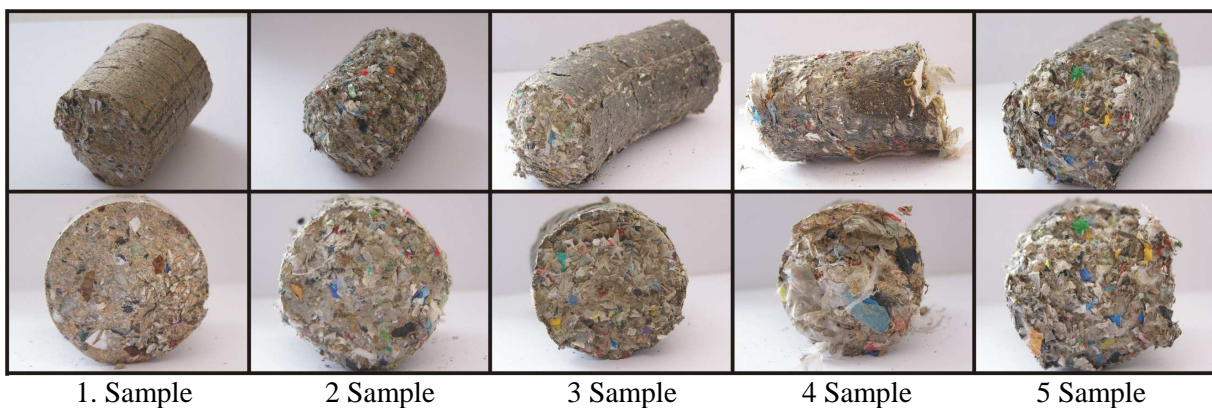

Fig. 5 Briquettes from various compounded materials

The briquettes were pressed from 5 different samples of compounded material containing plastic, carton, textile, wood and other type of waste material.

1. sample – RDF from mixed municipal waste consisted of: 38 % wood chips from soft wood, 45 % disintegrated carton waste, 11 % disintegrated PET bottles, 6 % textile waste
2. sample – RDF with addition 20 % of disintegrated carton waste
3. sample – RDF with addition 4 % of cement
4. sample – RDF with addition 20 % of wood sawdust
5. sample – RDF clear, without any additions

The briquette samples pressed from compounded waste material are presented Fig. 5.

From each group of the samples (1...5) the quality of seven briquettes was evaluated. Briquettes must be equal in composition; cracks and fine particles separation are not acceptable. The diameters and length of each briquette were measured before testing. Briquettes with higher density have longer burning time. The briquettes were placed between two round dies of testing press about diameter 30 mm to the centre of the die surface. The results of the briquettes testing are presented in Table 1.

TABLE 1.
RESULTS OF THE BRIQUETTES TESTING

No of Sample	Density of briquette, kg/m ³	Strength of the Briquette (cleft), MPa
1.	961	10,9
2.	779	20,3
3.	814	45,0
4.	675	15,7
5.	729	30,3

As it follows from the test results the mechanical strength of the briquettes obtained from only RDF wastes was quite low. Mixing the municipal waste with wood and paper waste increases both tested parameters of briquettes.

B Evaluation of the physical parameters in briquetting process

One of the important factors is pressing temperature which has significant impact on briquette quality and strength. This parameter influences the excretion of lignin from cellular structure of wood. Lignin plays very important role in compacting process; it has function of joining the fibres of pressed material. In Fig. 6 the dependence of the briquette strength on pressing temperature is demonstrated.

As it appears from the graph, it is not necessary to use the highest pressing temperature. The optimal pressing temperature is in that part of the curve where the maximum briquette strength properties are achieved. When the temperature is lower than optimal value the briquette is unstable, has lower strength which causes faster decay by burning. Also the briquette burns shorter time and less heat is generated in the process. By increasing the pressing temperature the volatile elements can be burned out from pressed material. Usage of higher compacting temperatures will cause the escape of volatile elements or pressing material

can begin to burn. With increasing of pressing temperature when compacting pressure is constant the higher values of briquette strength could be achieved, but only to the some extent.

Second important factor which influence mainly briquette strength is compacting pressure. Briquettes strength increases with increase of the pressure of the process. Briquette strength can be increased only to the strength limit of compacting material. Briquette strength has impact on briquette durability, because when the strength increases the absorption of atmospheric humidity decreases. Compacting pressure is very interesting and also very complicated parameter. Compacting pressure can be affected by various parameters e.g. type of pressing material; temperature in pressing chamber; material temperature; dimensions (length, diameter) and shape of pressing chamber; compacting procedure. Compacting procedure has impact on layers distribution in briquette and so on briquette strength. In Fig. 7 the dependence of briquette density on compacting pressure is described. The difference of compacting of warm material (200 °C) and material at room temperature (20 °C) are pointed out. The pressing at high temperature enables to obtain the briquettes with better densities at lower pressures. Briquettes have uniform shape and volume without visible cracks and scratches.

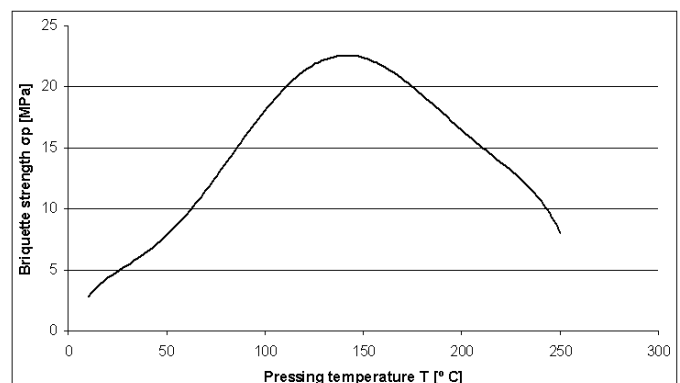

Fig.6 Dependence of briquette strength on pressing temperature [8]

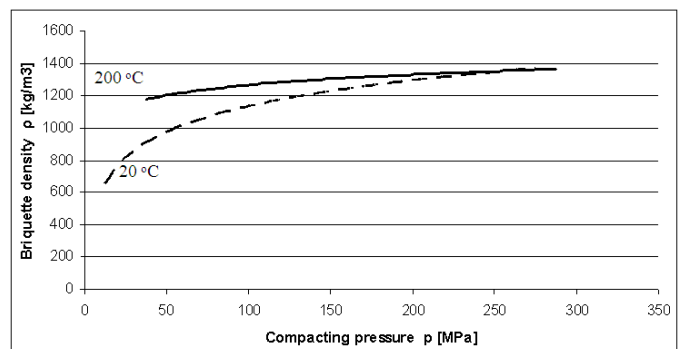

Fig.7 Dependence of briquette density on compacting pressure at various temperatures [8]

Third important factor is moisture content, which depends on the material type and specific properties. Several experiments were done to measure the influence of material moisture content at briquetting process. From the Fig. 8 it

follows that the optimal material moisture content is in the interval from 10 % to 18 %. These values are also given in scientific papers about suitable values of material moisture content for briquetting. Dependence of the briquette density on briquette moisture content is shown in Fig. 8. As it follows from the graph, briquettes with lower moisture content than 10% or higher than 18% are not suitable for subsequent burning process. Either if material moisture content is very low or very high (it means out of interval 10-18%), material elements are not consistent and briquette is falling to pieces. When the material moisture content is very high, the vaporization of surplus water tears the briquette to pieces. When the material moisture content is very low (fewer than 10 %), for briquette quality the higher pressures should be used and it is very expensive and uneconomic.

At Slovak University of Technology in Bratislava the numbers of experiments were performed and main influencing parameters of briquetting process were evaluated. The results of the parameters interaction are shown in Fig. 9.

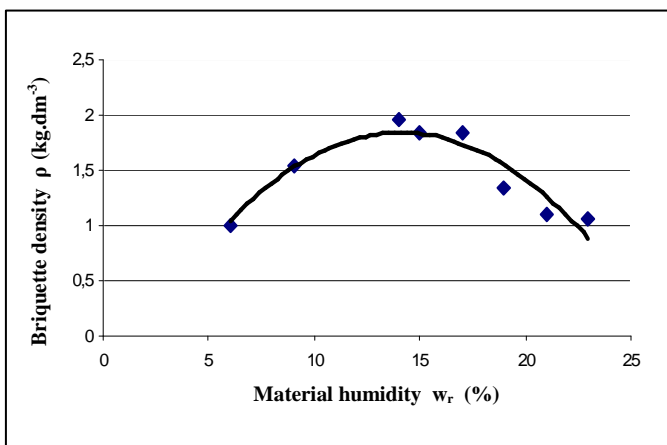

Fig.8 Dependence of the briquette density on material moisture content [8]

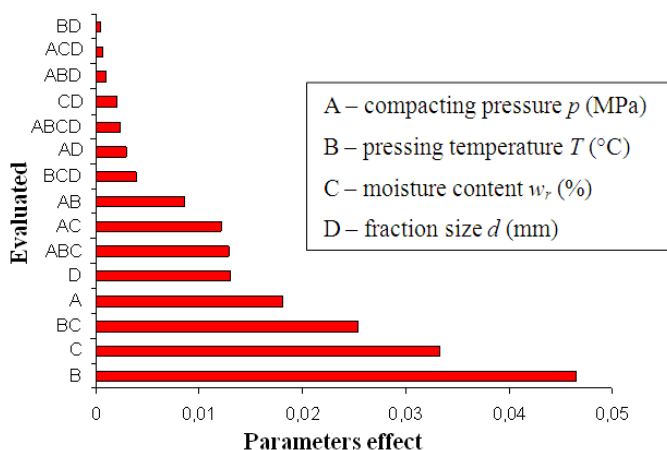

Fig.9 Influence of parameters and their mutual interactions at briquetting process [7]

This graph shows that the greatest influence on the briquette quality has pressing temperature, then materials moisture content and than mutual interaction of pressing temperature and material moisture content. Therefore material moisture

content should be reduced before briquetting by drying process.

Lower moisture content improves briquette quality.

On the “fourth” place in the influence influence evaluation graph (Fig.6) is compacting pressure, which is followed by fraction size. Influence of compacting pressure at briquetting process is described earlier in this paper. Fraction size has also very high influence at briquetting process. The coarser the fraction is the higher compacting power is needed for briquetting. Briquette has lower homogeneity and stability. With increasing the fraction size the binding forces inside the material are decreasing which effects on faster decay by burning (briquette burns faster and that is not an advantage). Fraction size enlargement raises the compacting pressure and decreases briquette quality. Smaller fraction size is also advantage in drying process. The drying process ends faster and better drying quality is achieved because material is disintegrated into smaller pieces. Therefore the waste material should be grinded into suitable fraction size and dried into certain moisture content before briquetting process.

IV CONCLUSIONS

The results of the briquetting parameters interaction study showed that biggest influence to the briquette quality has pressing temperature, then materials moisture content and than mutual interaction of pressing temperature and material moisture content.

The mechanical strength of the briquettes obtained from only RDF wastes was quite low. Therefore the wood and paper wastes have to be added to the plastic and municipal waste. When wood and paper wastes are mixed with municipal wastes and then this mix was briquetted the briquette strength increased 1.5-4.5 times. Material warming at briquetting process enables the reduction of compacting pressure without contraction of qualitative properties of the product. Therefore it is recommended to attach the heating equipment to the briquetting press for briquetting of plastic and municipal waste (It will increase the qualitative properties of the briquette. The final product briquettes from municipal wastes (RDF) or compounded plastic wastes could be used by gasification technology for heat obtaining. In the next step the combustion characteristics (ignitability, calorific value, flue gasses and ash content) should be evaluated.

REFERENCES

- Islam, R. F., et. al, Renewable energy resources and technologies practice in Bangladesh, *Renewable and Sustainable Energy Reviews*, 12 (2008), P 299–343
- Paulrud, S., Nilsson, C., Briquetting and combustion of spring-harvested reed canary-grass: effect of fuel composition, *Biomass and Bioenergy*, 20 (2001), P 25-35
- Yaman, S., et. al, Production of fuel briquettes from olive refuse and paper mill waste, *Fuel Processing Technology* 68, (2000), P 23–31
- Singh, R.N., Bhoi, P.R., Patel, S.R., Modification of commercial briquetting machine to produce 35mm diameter briquettes suitable for gasification and combustion, *Renewable Energy* 32 (2007), P 474–479
- Paist, A., Kask U, Kask L, et al., [Potential of biomass fuels to substitute for oil shale in energy balance in Estonian energy sector](#), Proceedings of Estonian Academy of Science Engineering, 22, 1, (2005), P 369-379
- Demirbas, A. Physical properties of briquettes from waste paper and wheat straw mixtures, *Energy Conversion & Management* 40 (1999) P 437-445

7. Križan, P., Wood waste compacting process and conception of presses construction, Dissertation thesis, FME STU in Bratislava, 2009 (in Slovak)
8. Križan, P., Pressing temperature, compacting process, material humidity and their mutual interactions, In.: Proceedings of specialized seminar Energy from Biomass V., Brno Czech Republic, 2006, 23.-24.11.2006, P 53-57 (in Slovak)

Jaan Kers, PhD., Senior Researcher, Department of Materials Engineering, Tallinn University of Technology, Ehitajate tee 5, 19086 Tallinn, Estonia, tel.: +372 620 3353, e-mail: jaan.kers@ttu.ee

Peter Krizan, MSc., PhD Student, Institute of Manufacturing Systems, Environmental Technology and Quality Management, Slovak University of Technology in Bratislava, Nám. Slobody 17, 812 31 Bratislava, Slovak Republic, tel.: +421 2 572 96 537, e-mail: peter.krizan@stuba.sk

Martin Letko, MSc., PhD Student, Institute of Manufacturing Systems, Environmental Technology and Quality Management, Slovak University of Technology in Bratislava, Nám. Slobody 17, 812 31 Bratislava, Slovak Republic, tel.: +421 2 572 96 537, e-mail: martin.letko@stuba.sk

Jaans Kers, Pēteris Križans, Martins Letko. Kompoundētu plastmasas atkritumu briketēšana kā mehāniskās reciklēšanas paņēmieni.

Šajā pētījumā aprakstīta plastmasas atkritumu briketēšana, kā mehāniskās reciklēšanas un materiālu pievienotās vērtības paaugstināšanas paņēmieni. Dažādi atkritumu veidi (koks, kartons, papīrs, plastmasa, tekstilijas) tika pārstrādāti divass un viensass smalcinātājos, lai iegūtu izejas produktu 1-2 mm diametrā, kas ir piemērotas briketēšanas procesam. Paraugu izgatavošanai izmantoja briketēšanas iekārtu, kura izgatavota Slovāku Tehnoloģijas universitātē Bratislavā. Briketes tika presētas no 5 dažādiem kompoundētā materiāla paraugiem, kuri saturēja plastmasu, kartonu, tekstilmateriālus, koku un citus atkritumu materiālu tipus. Tehnoloģiskie testi parādīja, ka sadzīves atkritumu briketēšanai nepieciešami augstāka presēšanas temperatūra un kompaktēšanas spiediens. Lai novērtētu izgatavoto brikešu kvalitāti, noteica to blīvumu un stiprības īpašības. No atkritumiem iegūta kurināmā mehāniskā stiprība pieauga pēc samaisīšanas ar koka un papīra atkritumiem. Parādīta arī dažādu parametru (frakcijas izmēri, mitruma saturs, kompaktēšanas spiediens un temperatūra) ietekme uz brikešu kvalitāti.

Яан Керс, Петер Крижан, Мартин Летко. Механическая переработка компондированных пластиковых отходов для повышения ценности материала путем брикетирования.

В данной статье описывается технология утилизации пластмассовых отходов путем брикетирования. Различные виды отходов (древесина, картон, бумага, пластмасса, текстиль) были переработаны на различных дробилках для получения дробленки размером 1-2 мм, которая пригодна для процесса брикетирования. Для изготовления образцов было использовано оборудование разработанное в Словакском Технологическом университете в Братиславе. Брикететы были отпрессованы из 5 различных образцов компондированных материалов содержащих пластик, картон, текстиль, дерево и другие виды отходов. Испытание показали, что брикетирование бытовых отходов требует более высокие температуры и давление прессования. Для оценки качества выпускаемых брикетов были определены прочностные свойства и плотность. Механическая прочность брикетов увеличилась с добавлением древесных и бумажных отходов. Было представлено влияние различных параметров (размер фракций, содержание влажности, температура и давление прессования) на качество брикетов.