

# Comparison of Induction Motor Transient Processes Characteristics Obtained Experimentally With Those Obtained by Means of FORTRAN and MATLAB Softwear

Guntis Orlovskis<sup>1</sup>, Marina Konuhova<sup>2</sup>, Karlis Ketners<sup>3</sup>, Riga Technical University

**Abstract-** in this article there is made comparison of induction motor real transient processes data given from mathematical model and experimental way. Theoretical investigation of induction motor was executed under two software – MATLAB and FORTRAN. The MATLAB soft induction motor model is created as a completed set. In FORTRAN there is created calculation algorithm. In both above mentioned soft there are fixed similar conditions. It was experimentally examined 300 W induction motor.

**Keywords** – FORTRAN, induction motor, mathematical model, MATLAB/Simulink, transient processes.

## I. INTRODUCTION

Last decades the problem of inductive motors (IM) efficiency becomes more and more actual. As we know from [1-5] references, IM is most used driver because of it hasn't brushes or magnets, therefore its expenses are small and IM structure is simple and maintenance is cheap. Nowadays wide used different control devices to operate IM rotor rotation frequency, for instance frequency converters or soft starters [9]. Using these devices it comes up the moments when motor circuit is switched off power supply.

The aim of this article is to compare both above mentioned soft and to choose soft able to solve transient processes when IM fed by frequency converter.

The transient processes are prompt changes in IM proceeding regime, for instance start-up, brake, load change, feeding voltage frequency change etc. To simplify the problem there is used in experiments IM with phase-wound rotor to avoid currents in rotor circuits. We know that the voltage on motor terminals doesn't drop to zero instantly, but decreases in accordance with rotor circuit electromagnetic time constant. In the rotor circuit residual flux induces current surge.

From [6] originator the inductive motor might be substituted by equivalent diagram on the Fig.1.

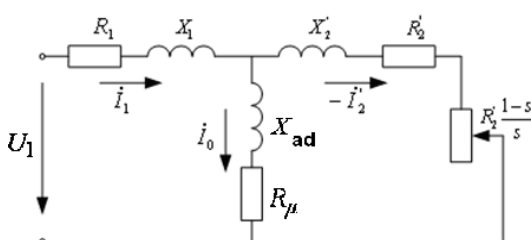

Fig.1. Equivalent circuit diagram of induction motor.

To compare transient processes starting motor on idle and under load it was characterized curves using FORTRAN and MATLAB. There were used standardized inductive motor T-type schemes in soft. Parameters are presented in Table 1.

Very big importance has rational IM use, thus it arises necessity to decrease losses maximally. Taking into account this problem importance one of the best problem solutions is to research transient processes using mathematical model.

## II. INDUCTION MOTOR MATHEMATICAL MODEL

Traditionally IM drive control devices are based on DC motor theory. It might be real induction motor substituted by mathematical equations using differential or voltage equations [6,7].

It is possible easily to investigate different IM processes using voltages, currents and flux linkages as a variable values. In both above mentioned soft IM mathematical model is solved in similar coordinate systems. To model motor transient processes in MATLAB Simulink there was used two phase mathematical model in synchronous rotating coordinate system. There is used Runge Kute method to calculate data in FORTRAN for this model. In both soft there are designated similar differential equations:

$$\left. \begin{aligned} V_{qs} &= R_s i_{qs} + \frac{d}{dt} \Psi_{qs} + \omega \Psi_{ds} \\ V_{ds} &= R_s i_{ds} + \frac{d}{dt} \Psi_{ds} - \omega \Psi_{qs} \\ V_{qr} &= R_r \hat{i}_{qr} + \frac{d}{dt} \Psi_{qr} + (\omega - \omega_r) \Psi_{dr} \\ V_{dr} &= R_r \hat{i}_{dr} + \frac{d}{dt} \Psi_{dr} - (\omega - \omega_r) \Psi_{qr} \end{aligned} \right\}; \quad (1)$$

$$T_e = 1.5p(\Psi_{ds} \hat{i}_{qs} - \Psi_{qs} \hat{i}_{ds}). \quad (2)$$

Flux linkages solutions:

$$\left. \begin{aligned} \Psi_{qs} &= L_s \hat{i}_{qs} + L_m \hat{i}_{qr} \\ \Psi_{ds} &= L_s \hat{i}_{ds} + L_m \hat{i}_{dr} \\ \Psi_{qr} &= L_r \hat{i}_{qr} + L_m \hat{i}_{qs} \\ \Psi_{dr} &= L_r \hat{i}_{dr} + L_m \hat{i}_{ds} \end{aligned} \right\}; \quad (3)$$

$$\left. \begin{aligned} L_s &= L_{ls} + L_m \\ L_r &= L_{lr} + L_m \end{aligned} \right\} \quad (4)$$

Equations for mechanical values:

$$\frac{d}{dt} \omega_m = \frac{1}{2H} (T_e - F\omega_m - T_m); \quad (5)$$

$$\frac{d}{dt} \Theta_m = \omega_m. \quad (6)$$

Decryption of parameters:

- Rs, Lls - Stator resistance and leakage inductance,
- R'r, L'lr - Rotor resistance and leakage inductance,
- Lm - Magnetizing inductance,
- Ls, L'r - Total stator and rotor inductances,
- Vqs, iqsq - axis stator voltage and current,
- V'qr, i'qrq - axis rotor voltage and current,
- Vds, idsd - axis stator voltage and current,
- V'dr, i'drd - axis rotor voltage and current,
- Ψqs, Ψds - Stator q and d axis fluxes,
- Ψ'qr, Ψ'dr - Rotor q and d axis fluxes,
- Ψm - Angular velocity of the rotor,
- Ψm - Rotor angular position,
- p-Number of pole pairs,
- Θr - Electrical angular velocity,
- Θr - Electrical rotor angular position,
- Te - Electromagnetic torque,
- Tm - Shaft mechanical torque.

At Fig.2 there is in MATLAB soft created scheme, where contactors connects IM to three phase feeder.

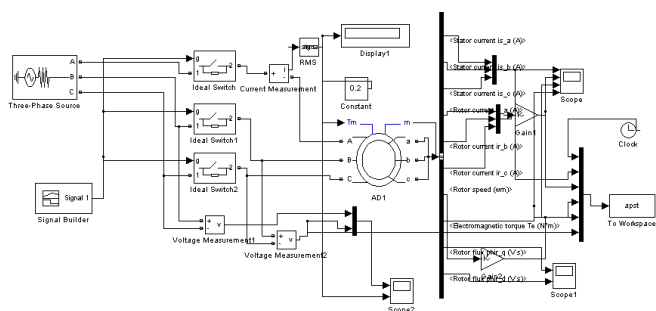

Fig.2. Mathematical model in MATLAB soft.

### III. TEST STAND FOR INDUCTION MOTOR.

The practical exercises were made on Leroy Sommer produced stand (Fig.3).

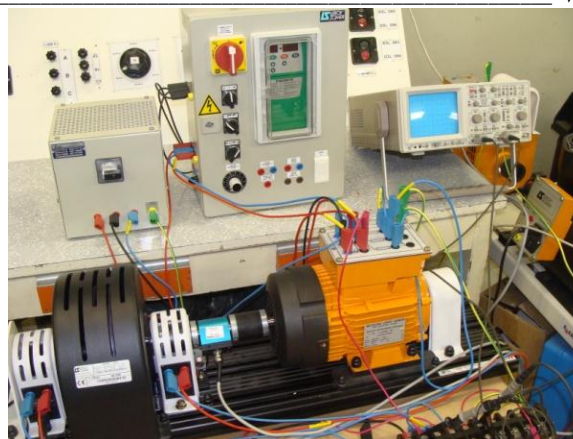

Fig.3. Induction motor testing stand

Stand contains inductive motor with phase rotor, torque sensor, electromagnetic brake and tacho-generator. IM transient processes were fixed without resistance in secondary circuit. The current was measured by measurement outfit. HAMEG oscilloscope was used for data acquisition and transmission to personal computer

Induction motor parameters might be defined different way but to simplify calculations they are counted on no-load and locked rotor measurements base [6]. In calculations there are not taken into account iron losses.

Nominal parameters of induction motor:

$$P_n = 300W, U_n = 220V, I_n = 1.1A$$

TABLE I  
IM EQUIVALENT CIRCUIT PARAMETERS

Parameters	PU units	SI units
$R_s$	0.127	25.4
$X_s$	0.108	0.069
$X_M$	1.021	0.65
$X_r$	0.108	0.069
$R_r$	0.124	24.8

There should be involved moment of inertia value in IM mathematical model calculation in both soft. It is calculated in accordance with [8].

$$J = \left(\frac{30}{\pi}\right)^2 P_m \frac{\Delta t}{n_N \Delta n}, \quad (7)$$

where  $P_m$  – mechanical losses (W),  $n_N$  – nominal rotation frequency ( $\text{min}^{-1}$ ),  $\Delta n$  – speed difference ( $\text{min}^{-1}$ ),  $\Delta t$  – time difference (s).

The moment of inertia was defined basing on motor rundown test  $J = 0.035 \text{kgm}^2$ . Friction coefficient calculation based on mechanical losses summarized with braking mechanical losses. IM has 300W capacity; therefore it allows researching complicated transient processes because there are no large current increases able to involve network voltage.

#### IV. COMPARISON OF RESULTS

Residual voltage on IM terminals shown on Fig.4. Current in rotor circuit arises in interconnection with voltage and residual flux.

Using induction motor with phase rotor there was taken current changes in rotor windings in 0.5 sec after switch opening, in experiment it was taken only one phase (Fig.5).

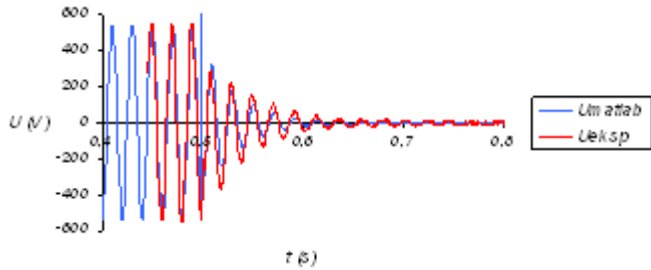

Fig.4. Residual voltage on IM terminal

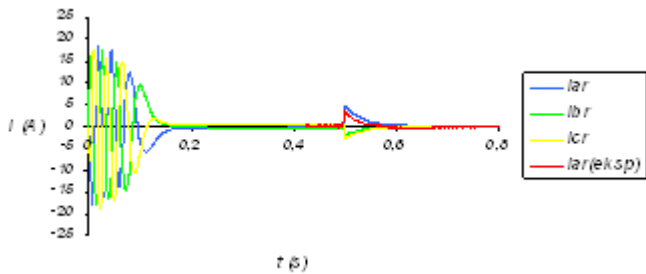

Fig.5. Current in rotor after switching opening

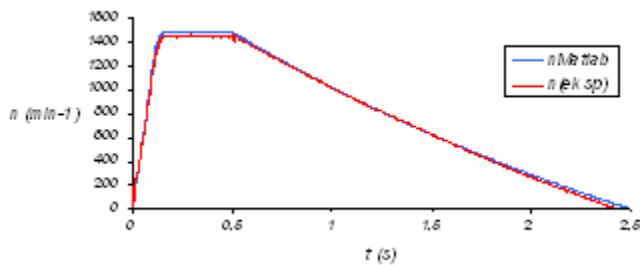

Fig.6. Rotation frequency at start-up and rundown

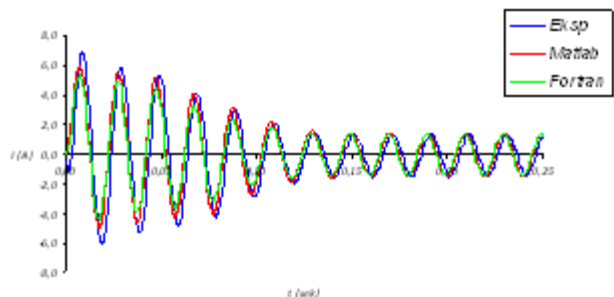

Fig.7. Stator current at no-load

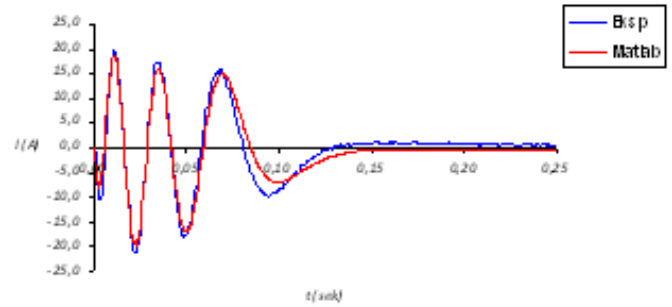

Fig.8. Rotor current at no-load

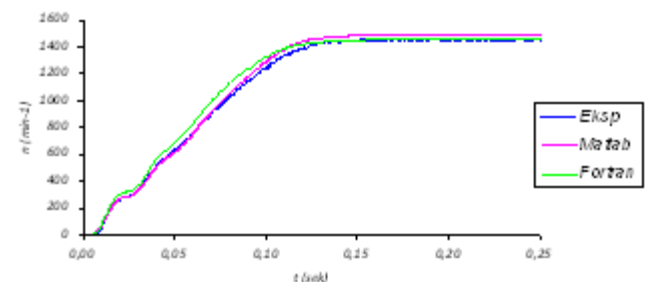

Fig.9. Rotor rotation frequency at full load

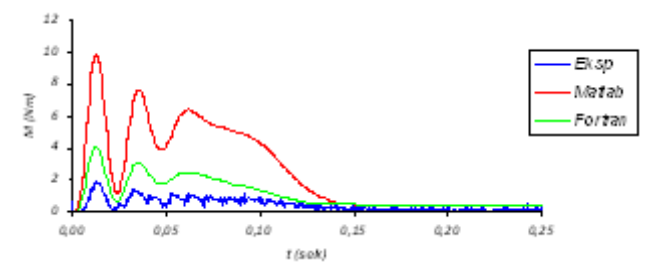

Fig.10. Electromagnetic torque at no-load

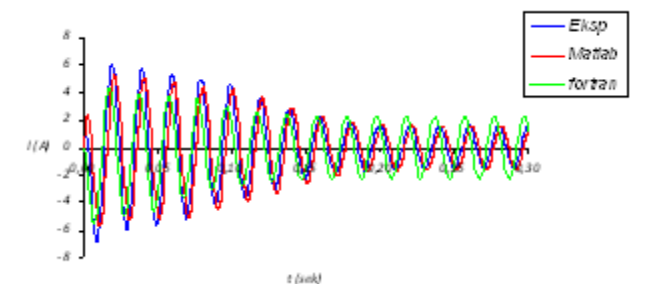

Fig.11. Stator current at full load

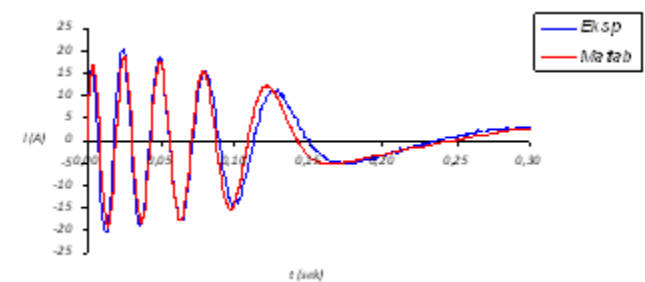

Fig.12. Rotor current at full load

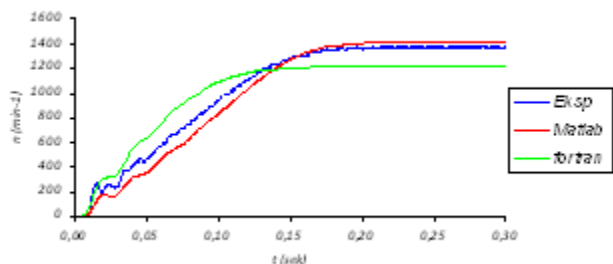

Fig.13. Rotor rotation frequency at full load

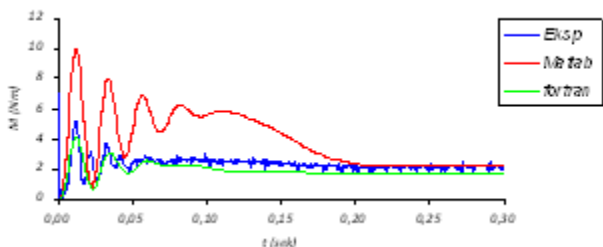

Fig.14. Electromagnetic torque at full load

In practice there is very difficult to define moment of inertia of electric machine therefore it was found of rundown curve (Fig.6). As we can see from curves the moment of inertia and friction determine brake time. Choosing larger moment of inertia starting time increases.

At Fig.7 there is shown stator one phase current at motor start-up. Motor starts at no-load but at Fig.11 motor starts at nominal load. In FORTRAN calculated current is larger because it wasn't taken into account motor friction but load value increased.

Differences appearing in stator and rotor currents (Fig. 7 and 8) could be described by voltage change because in both soft it has initial value equal to zero, but in experiment connecting scheme every time the angle is different. At Fig.9 speed curves at no-load concur but at Fig.13 starting motor at 2 Nm load in FORTRAN we see differences, that might be described by wrong load torque determination in initial data. Decreasing load value in FORTRAN it will decrease current in stator circuit and increase rotor rotation frequency. At Fig.10 and 14 we could see that in MATLAB soft electromagnetic torque succeed very large deviations at start but in FORTRAN soft and in experiment deviations are rather smaller. That might be described by sensor sensitivity and interconnection between electromagnetic and load torques at short time intervals.

In both soft equivalent circuit parameters are fixed as a constants, but in practice when motor slip is near to critical value parameters change.

## V. CONCLUSIONS

Data received by both soft are identical. Differences between received results might be described by imprecise parameters determination. As far transient processes are very short, the differences of currents values are not important. The differences are observed at mechanical values starting motor at

full load that might be described by IM equivalent circuit diagram parameters changes at start.

Preferences of modeling in MATLAB: quick and suitable data insert and receiving, opportunity to supplement the model by different electric elements, but in MATLAB impossible to change parameters values during transient processes.

Programming in FORTRAN it is possible initial data insert as a variable function depending on time or slip. But there are imperfections in this soft, for instance there is no regime of visual curve observation, the file should be saved in special format and it should be opened by another program, which asks to spend a lot of additional time.

Received curves show that created programs are correct and it allows solving complicated transient processes in IM. We see that by above mentioned programs it is possible to replace real IM. Creating program which considers equivalent circuit diagram parameters change we'll get more precise results. Using soft it is possible to succeed conditions when we don't need to make electrical measurements to check the changes of currents, voltages, rotor rotation speed or electromagnetic torque during transient processes.

## ACKNOWLEDGMENT

This work has been supported by the European Social Fund within the project „Support for the implementation of doctoral studies at Riga Technical University”.

## REFERENCES

- [1] M. Ikeda, T. Hiyama, Simulation studies of the Transients of Squirrel-Cage Induction Motor, IEEE Power and Energy Society, Vol 22, p. 233-239, 2007;
- [2] Cui Xueshen, Yang Yulei, Zhou Zhenhua and Zhao Haisen. The research on residual voltage of asynchronous motors and its impact on power restoration. IEEE Electric Utility Deregulation and Restructuring and Power Technologies, DRPT 2008. pp. 2333-2338, 2008.
- [3] Aiyuan W, Zhihao L, Wenbo L. Residual voltage analysis in reclosing process for induction machine. IEEE Proceedings of 7th World Congress on Intelligent Control and automation. Chongqing, China. pp. 4785-4788. June 2008;
- [4] Pedra J., Estimation of typical squirrel-cage induction motor parameters for dynamic performance simulation, IEE Proceedings Generation, Transmission and Distribution, vol 153, p. 137-140, 2006;
- [5] Faiz J., Ghaneei M., Keyhani A. „Performance analysis of fast reclosing transients in induction motors.” IEEE Trans. Energy Conversion Vol.14, No. 1. pp. 101-107. March 1999.
- [6] P.C. Krause, O. Wasynczuk, S.D. Sudhoff, Analysis of Electric Machinery and Drive Systems, IEEE Press, Wiley-Interscience, Second edition 2002. – 614 p;
- [7] Копылов И.П. Математическое моделирование электрических машин: Учеб. Для вузов.-3-е изд. перераб. И доп.- М.: Высш.шк., 2001.-327 с.: ил;
- [8] О. Д. Гольдберг, Испытания электрических машин, Высшая Школа, Москва 2000.-256с,
- [9] Bin Wu, High-Power Converter and AC Drives, Jon Wiley and Sons, Chapter 14 p.285-296., 2006.



**Guntis Orlovskis,**  
Mg.Sc.Ing., PhD student  
Riga Technical University,  
Power Engineering Institute  
Address: Kronvalda blv., 1, LV-1010, Riga,  
Latvia  
Phone: +3717089927  
Email: [jott@inbox.lv](mailto:jott@inbox.lv)



**Marina Konuhova**  
Mg.Sc.Ing., PhD student  
Riga Technical University,  
Power Engineering Institute  
Address: Kronvalda blv. 1, LV-1010, Riga,  
Latvia  
Phone: +371 29691890, fax 67089418  
Email: [Marina.Konuhova@rtu.lv](mailto:Marina.Konuhova@rtu.lv)



**Karlis Ketners**  
Professor, Dr.Sc.Ing.  
Riga Technical University,  
Power Engineering Institute  
Address: Kronvalda blv. 1, LV-1010, Riga,  
Latvia  
Phone: +371 67089926, fax 67089418  
Email: [ketners@eef.rtu.lv](mailto:ketners@eef.rtu.lv)