

**MECHANICS IN THE INSTITUTIONS OF HIGHER EDUCATION OF LATVIA****MEHĀNIKA LATVIJAS AUGSTSKOLĀS**

**Vitauts Tamuzs**, professor, Dr.habil.sc.ing.  
University of Latvia, Institute of Polymer Mechanics  
Address: 23 Aizkraukles Street, Riga, LV – 1006, Latvia  
Phone: +371 67543306, Fax: +371 6782067  
E-mail: tamuzs@pmi.lv

**Jānis Vība**, professor, Dr.habil.sc.ing.  
Riga Technical University, Institute of Mechanics  
Address: 6 Ezermalas Street, Riga, LV – 1006, Latvia  
Phone: +371 67089473, Fax: +371 67089746  
E-mail: janis.viba@rtu.lv

*Keywords: history of mechanics, Riga Polytechnic, Academia Petrina, Peter Biron, Wilhelm Ritter, Friedrich Zander, N. Rozenauer, J. Panovko, O. Ozols, O. Kepe*

## **1. Introduction**

The article gives a historical review of development of Mechanics in Latvia from the 18<sup>th</sup> century till the present time. Main attention is paid to the birth and development of the studies of Mechanics after the Second World War.

It is shown that the fundamental subjects in the area of Mechanics are included in the study programmes of universities and institutions of higher education of Latvia. The article includes the list of the main scientific and textbooks in Mechanics written and published by Latvian scientists and professors. The main study programmes and courses in the institutions of higher education of Latvia are mentioned as well.

## **2. History**

The first works of mechanics in Latvia were related to the city of Jelgava, to the Academy of Peter or Academia Petrina – academic gymnasium, established by Peter Biron, the last duke of Courland [1, 2]. Academia Petrina was the first higher educational and scientific centre in Latvia, the beginning of which is dated with 1775 when Mitau Academic Gymnasium was established. Although Academia Petrina never gained the status of university, it had a lot of preconditions for it. The Academia was named in honour of the duke Peter Biron who was the first rector of the institution (Fig. 1).



Fig. 1. Peter Biron, the duke  
of Courland



Fig. 2. Jelgava Palace today

The regulations and education plan of Academia Petrina was worked out by academician J. G. Zulcer from the Berlin Academy of Science. Here professor of Mathematics Vilhelm Beitler (1745 – 1811) published proceedings about aerostatics of air-balloon and Latvian mechanic E. J. Binemanis designed and lifted up in air several air-balloons (1785). In 1862 the Riga Polytechnic was established. The further research in the field of Mechanics (till the First World War) was connected with this higher educational institution [3].

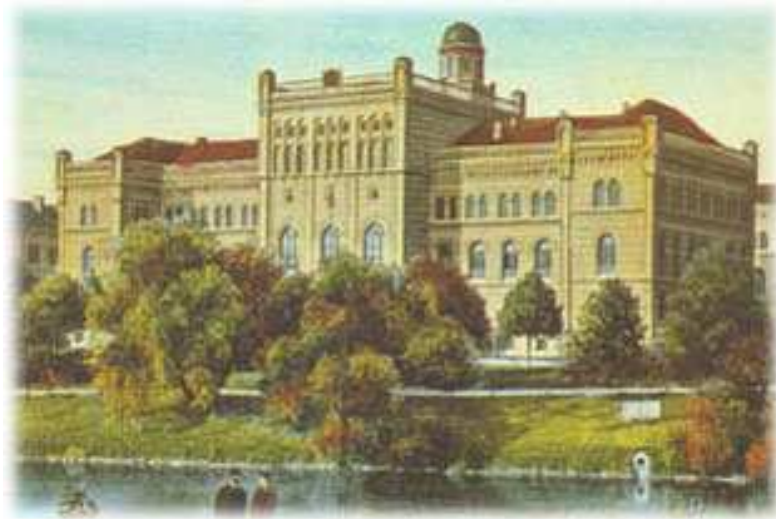

Fig. 3. Riga Polytechnic (Today – the main building of the University of Latvia)

Here should be mentioned Swiss Wilhelm Ritter (1847-1906) with works in graphical static [4],

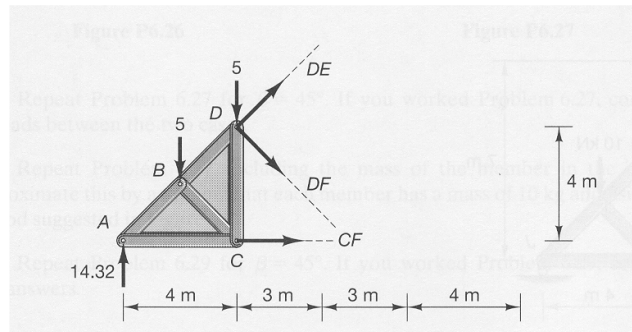
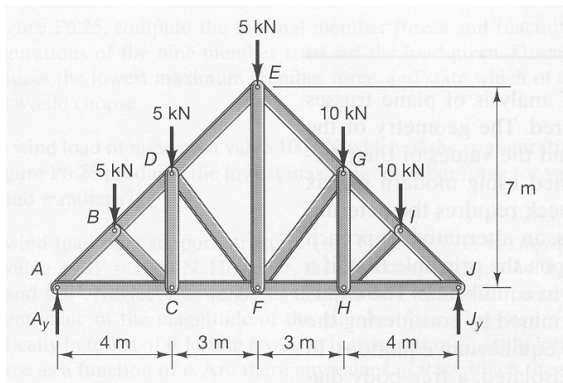

Fig. 4. Truss calculation. Ritter's points C, D and F

Piers Bohl (1865-1921) with work in celestial mechanics, and others. After the First World War a professor of University of Latvia Alfrēds Vītols (1878-1945) made research in theory of hydraulics and expanded activities in the international scientific work, but professor N. Rozenauer (1890-1970) made great investigations in kinematics of machines and mechanisms and in other fields [5, 6].

Also must be mentioned the outstanding engineer and inventor Friedrich Zander (1887-1933) who was born in Riga and graduated the Riga Polytechnical Institute (former Riga Polytechnic) (1914). Friedrich Zander (Russian: Фридрих Артурович Цандер, often transliterated *Fridrikh Arturovich Tsander*; Latvian: *Frīdrihs Canders*, 23.08.1887–28.03.1933) was a pioneer of rocketry and spaceflight in the Russian Empire and the Soviet Union. He designed the first liquid-fuelled rocket launched in the Soviet Union, GIRD-X, and made many important theoretical contributions to the road to space [7].



Fig. 5. Friedrich Zander

Nowadays the Latvian Academy of Science biennially awards a prize of Friedrich Zander in the field of mechanics and astronomy.

### 3. History of the books in Mechanics

All books published in the Latvian language could be divided in three groups.

The first group includes books published in Latvia from 1920 till 1940. Almost all publications are from the University of Latvia: many books of N. Rozenauer, as well as works of A. Vītols, J. Inveiss, E. Leimanis, J. Muižnieks, E. Veiss, E. Veidemanis and others.

The first remarkable author of textbooks in Mechanics in the Latvian language is N. Rozenauer. In thirty years working at the University of Latvia he published several books, mainly about the issues of kinematics.

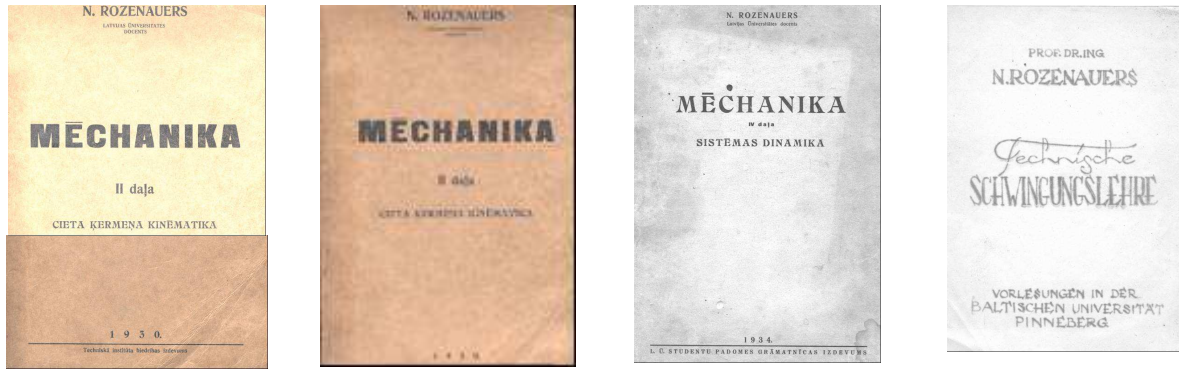

Fig. 6. Examples of the books written by N. Rozenauer

The second group includes books that are translated from the Russian language after the Second World War.

The third group includes books of Latvian professors, published in the period after the Second World War in different languages. In this group professors of LU, RTU and LLU have made the largest contribution. They have published many notes of lectures, practical and scientific works. From those noteworthy are the following books:

1. Panovko J., Leppiks A., Strēķis A. Course of Strength of Materials – Latvia State Press, Rīga, 1955 - 432 p. (In Latvian).
2. Ozols O., Strēķis A., Vasermanis J., Muižnieks A. Course of Theoretical Mechanics – Rīga, 1961 -565 p. (In Latvian).
3. Ozols O., Strēķis A., Vasermanis J., Muižnieks A. Course of Theoretical Mechanics – Zvaigzne, Rīga, 1966 - 616 p. (In Latvian).
4. Auzukalns J., Ceplītis E., Kalniņš I., Liepiņš I. Strength of Materials in Tasks – Zvaigzne, Rīga, 1973 - 742 p. (In Latvian).
5. Ozols O. Theory of Mechanisms and Machines – Zvaigzne, Rīga, 1974 - 418 p. (In Latvian).
6. Theoretical Mechanics in Exercises. Editor O. Kepe (authors: V. Akmentiņš, O. Kepe, E. Krūmiņš, J. Lauva, J. Miķelsons, A. Muižnieks, J. Svetins, J. Vība) – Zvaigzne, Rīga, 1976 - 647 p. (In Latvian).
7. Kuksenko V., Tamuzs V. Fracture Micromechanics of Polymer Materials – Riga, Zinatne, 1975 (in Russian); (English translation by Martinus Nijhoff Publ. 1981), - 310 p.
8. Kepe O., Vība J. Theoretical Mechanics – Zvaigzne, Rīga, 1982 – 577 p. (In Latvian).
9. Lavendelis E. Strength of Materials – Zvaigzne, Rīga, 1986 - 341 p. (In Latvian).
10. Short Tasks in Theoretical Mechanics. Editor O. Kepe – Moscow, Vissaja skola, 1989 - 368 p. (In Russian).
11. Romalis N., Tamuzs V. Fracture of Nonhomogenous Solids – Riga, Zinatne, 1989 – 224 p. (in Russian).
12. Theoretical Mechanics. Dynamics. Editors O. Kepe, J. Vība – Rīga, RTU, Part I - 1994 - 259 p. (In Latvian), Part II - 1996 - 174 p. (In Latvian), Part III - 1999 - 183 p. (In Latvian).
13. Altenbach H., Altenbach J., Rikards R. Introduction in Mechanics of Laminated and Sandwich Structures - Deutscher Verlag fuer Grundstoffindustrie, Stuttgart, 1996 - 410 p.
14. Dictionary of Mechanics Terminology (in 4 languages: Latvian, English, German, Russian). Editor V. Tamuzs – Publishing office "Latvian National Committee of Mechanics", Rīga, 1997 - 253 p.
15. Tamuzs V., Romalis N., Petrova V. Fracture of Solids with Microdefects – New York, Nova Science Publ., 2000 - 238 p.



Fig. 7. Examples of the textbooks

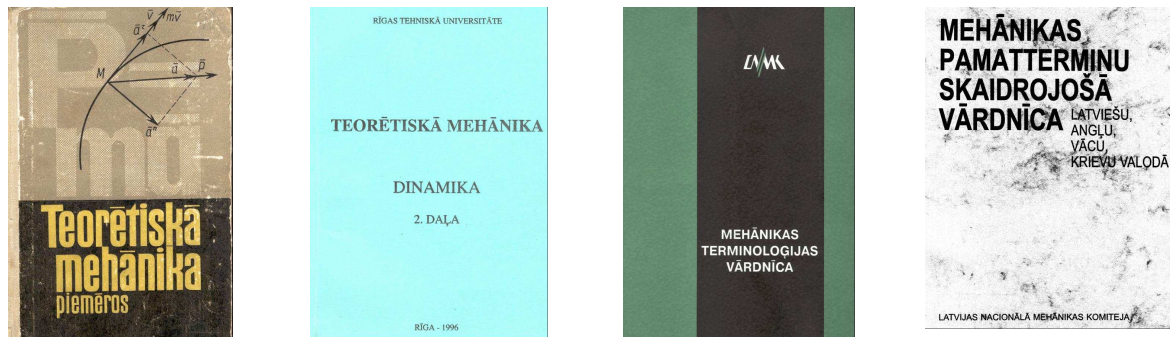
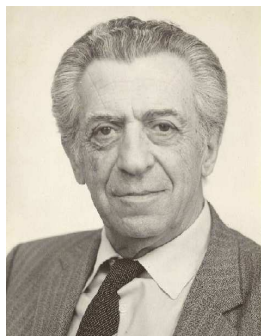

Fig. 8. Examples of books and dictionaries



Prof. J. Panovko  
Riga Polytechnical Institute



Prof. O. Ozols  
Latvia Academy of Agriculture



Prof. O. Kepe  
Riga Technical University

Fig. 9. Editors of the main books

#### 4. Education departments and courses of Mechanics in Latvia today

The content and quantity of the courses of Mechanics are different in the University of Latvia (LU), Riga Technical University (RTU), Latvia University of Agriculture (LLU), Latvian Maritime Academy (LJA) and other higher educational institutions of Latvia. However, their main goal is the same – to provide the students with a reliable explanation and sufficiently deep understanding about worldwide mechanical interactions and motions of objects and their

dynamics' analysis. It may be shown that courses of Mechanics form fundamental base for higher education in engineering sciences, they help students successfully study other subjects of Mechanic's cycle according to the profile and specialization of an institution of higher education.

According to the data of the Latvian National Committee for Mechanics (LNCM, Chair: prof. Vitauts Tamuzs) and LNCM Seminary (Chief: prof. Jānis Vība) there are the following education departments and courses of Mechanics in Latvia.

The first must be mentioned the Institute of Polymers Mechanics (director: Dr.habil.sc.eng. Juris Jansons) of the **University of Latvia (LU)**, Faculty of Physics and Mathematics. Studies and research in Mechanics are mainly carried out in the Bachelor's, Master's and Doctoral



Fig. 10. Students at the University of Latvia



Fig. 11. Laboratory equipment of the Institute of Polymers Mechanics

programmes of Physics and Mathematics. The main study courses in Mechanics are the following: Theoretical mechanics; Applied mechanics; Mechanics of solids; Fracture mechanics; Fatigue; Mechanics of continuous medium; Research in the field of electrodynamics; Theoretical and experimental research of the mechanical properties of materials; Mechanics of composite materials' constructions; Development of mathematical modelling methods for analysis of electromechanical processes, and others. <http://www.pmi.lza.lv/>.

In the Institute of Mechanics (director Dr.habil.sc.eng., prof. Jānis Vība) of **Riga Technical University (RTU)**, Faculty of Transport and Mechanical Engineering, Mechanics are studied (in Bachelor's Sc. Eng., Master's Sc. Eng. and Doctoral programmes) via the following courses: Engineering Technology; Mechanics and Mechanical Engineering;



Fig. 12. The main building of Riga Technical University

Production Technology; Railway transport; Auto transport; Aviation Transport. The elements of Mechanics are integrated also in the courses of Theoretical mechanics; Technical mechanics; Strength of materials; Dynamics and lasting of machines; Vibration and stability of technical systems; Numerical analysis in engineering mechanics; Investigation of impact systems; Analytical mechanics; FEM analysis of constructions; Non-linear dynamics and chaos; Biomechanics of muscle systems; Investigations of composite materials; Investigation of traffic accidents and others. <http://www.mi.rtu.lv/>.



Fig. 13. ARMFIELD wind tunnel at the Institute of Mechanics

In the Institute of Mechanics (director Dr.habil.sc.eng., prof. Guntars Uzklīnģis) of the **Latvian University of Agriculture (LLU)**, Faculty of Engineering, Mechanics is studied by the students of Bachelor's, Master's and Doctoral programmes in specialization in the Design of agricultural machinery; Production and maintenance of agricultural machinery; Forest exploitation; Timber cutting, and others. The elements of Mechanics are thought in the following courses: Theoretical mechanics; Technical mechanics; Applied mechanics; Strength of materials; Dynamics of machines and others. <http://www.cs.llu.lv/>.



Fig. 14. The main building of the Latvia University of Agriculture

In the Marine Engineering Department (director Dr.habil.sc.eng., prof. Juris Cimanskis) of the **Latvian Maritime Academy** Mechanics is studied mainly in the programmes of

specialization in the fields of analysis of the stability of ships', motion and dynamics of rotors (Bachelors', Masters', and Doctoral level).

In the study program "Marine Transportation – Marine Engineering" the main elements of mechanics are used in the courses: Theoretical mechanics; Strength of materials; Analytical mechanics; Theory of mechanical vibrations; Methods of optimizations; Dynamics and stability of ships motion. <http://www.aic.lv/ENIC/lat>



Fig. 15. Studies at the Latvian Maritime Academy

## Conclusion

The professors and students of the institutions of higher education of Latvia have very close contacts with students and scientists in the field of Mechanics of the Baltic region. They share their research and experience in conferences, e.g., International DAAAM conferences in Tallinn, Vibroengineering conference in Kaunas, the conference on Non-linear dynamics, Catastrophes and Chaos in Riga.

The professors of the higher educational establishments of Latvia take active part in international projects in the field of Mechanics and Mechanical engineering: prof. V. Tamuzs – “Fracture of Composite Materials”; prof. R. Rikards “Calculation of Laminated Composite Structures”, prof. I. Knēts “Problems of Biomechanics”, prof. J. Vība “Vibrations and Collisions in Connected Bodies’ Systems”.

## References

1. <http://serveris3.ailab.lv/kultura/kultura/angl02.htm>
2. <http://www.tripwolf.com/en/guide/show/301744/Latvia/Jelgava/Academia-Petrina>
3. [http://en.wikipedia.org/wiki/Riga\\_Technical\\_University#Riga\\_Polytechnicum.2C\\_1862-1918](http://en.wikipedia.org/wiki/Riga_Technical_University#Riga_Polytechnicum.2C_1862-1918)
4. Ritter W. Z. Bauwesen – 1877 - 189 p.
5. Vitols A. Essai d'établissement d'une théorie de l'écoulement des eaux pluviales. Acta Universitatis Latviensis IV, 1922 - 140 p.
6. Rosenauer N. Ein Graphoanalytisches Verfahren zur Bestimmung des Beschleunigungspoles und der Beschleunigungspolkurven der ebenen Bewegung – ZAMM, B. 18, Nr. 2, 1938. N. Rosenauer. Mechanismu kinematika - R., 1938.
7. [http://en.wikipedia.org/wiki/Friedrich\\_Zander](http://en.wikipedia.org/wiki/Friedrich_Zander)

### **Tamužs V., Vība J. Mehānika Latvijas augstskolās**

Rakstā sniegts mehānikas attīstības vēsturisks apskats Latvijā no XVIII gadsimta līdz mūsdienām. Atzīmēts, ka pirmais augstākās izglītības un zinātniskais centrs Latvijā bija Academia Petrina, kas dibināta 1775. gadā. Rakstā ir parādīts, ka mehānikas jomas izpētes fundamentālie jautājumi ir iekļauti Latvijas augstākās izglītības iestāžu un universitāšu studiju programmās, piemēram, Latvijas Universitātes, Rīgas Tehniskās universitātes, Latvijas Lauksaimniecības universitātes, Latvijas Jūras akadēmijas. Latvijas augstākās izglītības iestāžu galvenās studiju programmas un kursi ir labi novērtēti. Visas latviski publicētās grāmatas par mehāniku ir iedalītas trīs grupās. Pirmā grupa ietver grāmatas no 1920. gada līdz 1940. gadam; gandrīz visas ir Latvijas Universitātes profesoru publikācijas. Otrā grupa ietver grāmatas, kas tulkotas no krievu valodas pēc Otrā Pasaules kara. Trešā grupa ietver Latvijas profesoru grāmatas, kas publicētas dažādās valodās laikā pēc Otrā Pasaules kara. Rakstā ir iekļauts Latvijas profesoru un zinātnieku sarakstīto un publicēto galveno mehānikas mācību grāmatu un zinātnisko darbu saraksts.

### **Tamužs V., Vība J. Mechanics in the Institutions of Higher Education of Latvia**

The article gives a historical review of development of Mechanics in Latvia from the 18<sup>th</sup> century till the present time. Academia Petrina was the first higher educational and scientific centre in Latvia, the beginning of which is dated with 1775. It is shown that the fundamental subjects in the area of Mechanics are included in the study programmes of the institutions of higher education of Latvia: University of Latvia, Riga Technical University, Latvia University of Agriculture, Latvian Maritime Academy. The main study programmes and courses in the institutions of higher education of Latvia are mentioned as well. All books in Mechanics published in the Latvian language are divided in three groups. The first group includes books published in Latvia from 1920 till 1940; almost all publications are from the University of Latvia. The second group includes books that are translated from the Russian language after the Second World War. The third group includes books of Latvian professors published in the period after the Second World War in different languages. The article includes the list of the main scientific and textbooks in Mechanics written and published by Latvian scientists and professors.

### **Тамуж В., Виба Я. Механика в высших учебных заведениях Латвии**

В настоящей статье дан исторический обзор развития механики в Латвии, начиная с XVIII века до наших дней. Отмечено, что Academia Petrina, которая учреждена в 1775 году, была первым заведением высшего образования и научным центром в Латвии. В статье отражено, что вопросы фундаментальных исследований в области механики включены в учебных программах университетов и других учреждений высшего образования Латвии: Латвийского Университета, Рижского Технического университета, Латвийской Морской академии, Латвийского Сельскохозяйственного университета. Основные учебные программы и курсы по механике в высших учебных заведениях Латвии имеют общее признание. Все книги по механике, которые опубликованы на латышском языке, разделены на три группы. В первую группу включены книги, выпущенные с 1920 по 1940 год, в основном публикации профессоров Латвийского Университета. Ко второй группе относятся книги, переведённые с русского языка после Второй Мировой войны. Третья группа включает книги профессоров Латвии, которые опубликованы на разных языках в периоде после Второй Мировой войны. В статье включён список основных учебников и научных работ Латвийских профессоров и учёных.